

VERONICA (XL)

MEUBLE TV CONTEMPORAIN
AVEC LED

NOTICE DE MONTAGE

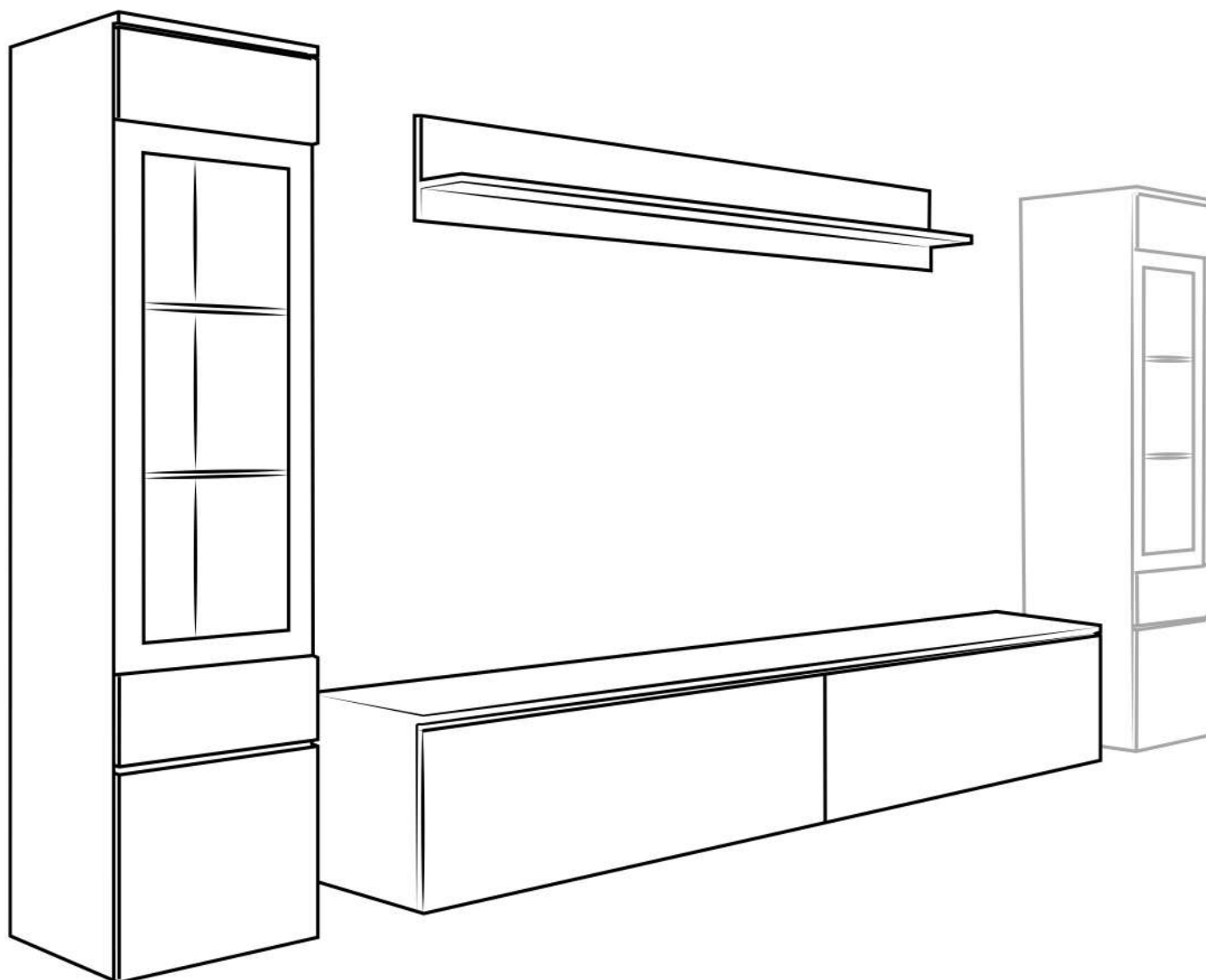

**DECO
IN PARIS**

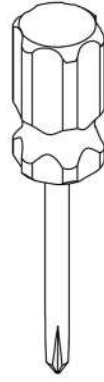
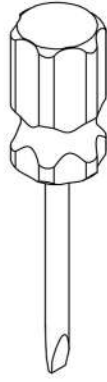
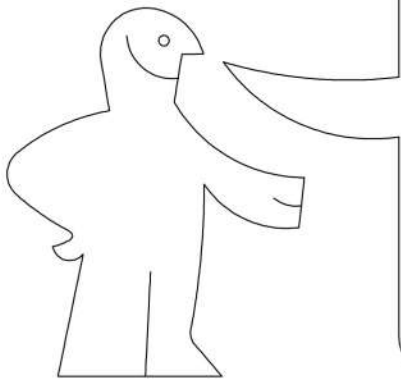



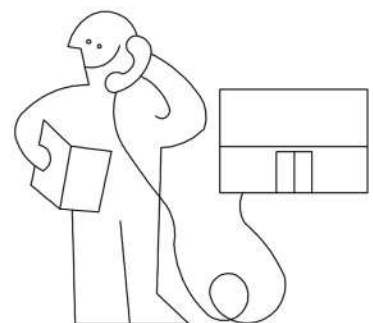
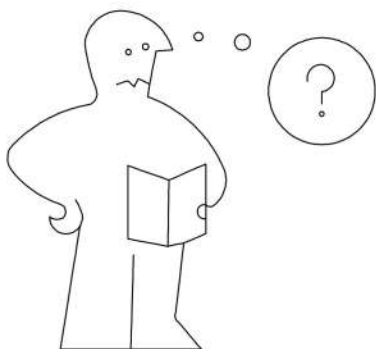
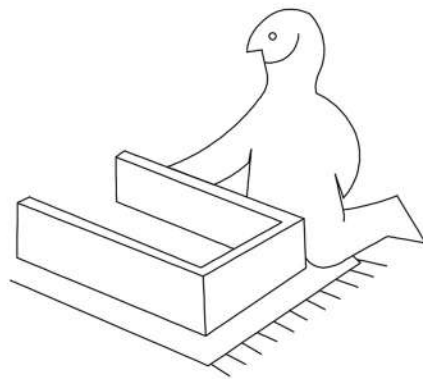
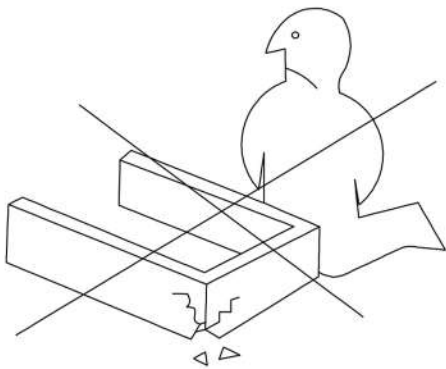
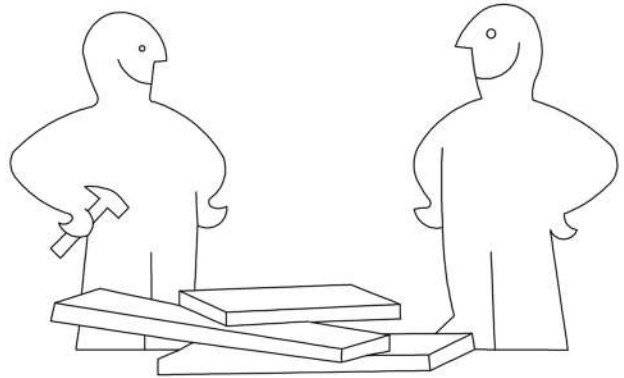
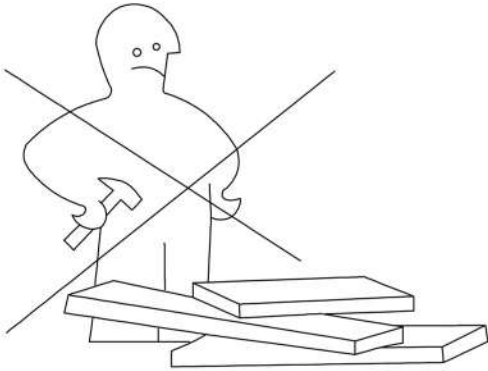



**DECO
IN PARIS**

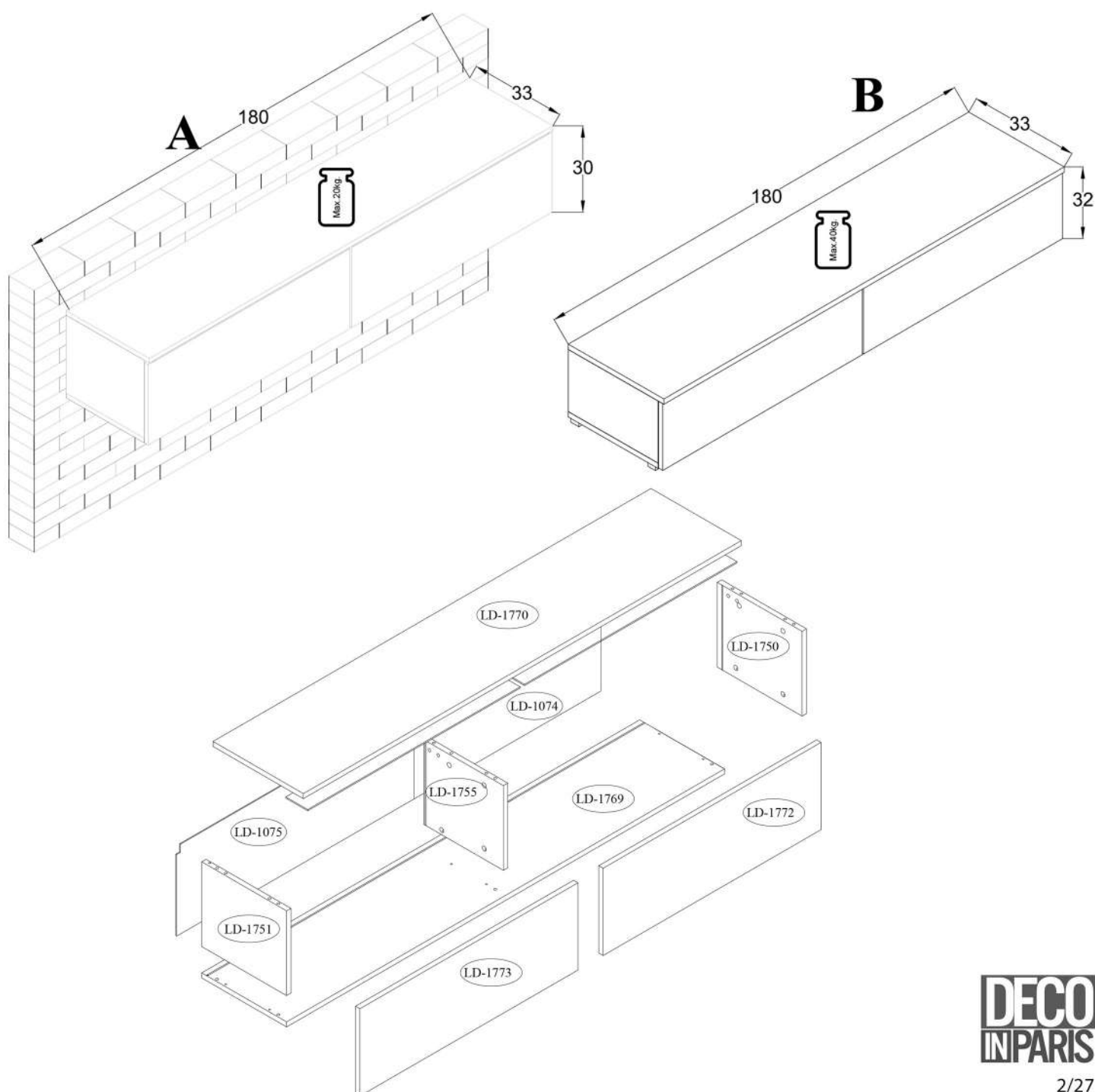







	Uwaga • Upozornini • Achtung • Attention • Caution • Figyelem Attenzione • Opgelet • Внимание • Atentie • Upozornenie • Dikkat 
<i>PL</i>	Czyszczenie należy wykonać wyłącznie za pomocą ściereczki lub lekko nawilżonego ręcznika. Nie stosować środków czyszczących do szorowania.
<i>CZ</i>	Čistení je nutné vykonávať výhradne pomoci utěrky nebo lehce navlhčeného ručníku. Nepoužívejte čističí prostředky obsahující abrazivní částice.
<i>D</i>	Bitte nur mit einem Staubtuch oder leicht feuchtem Lappen reinigen. Keine scheuernden Putzmittel verwenden.
<i>GB</i>	Please only clean with a duster or a damp cloth. Do not use any abrasive cleaners.
<i>F</i>	Le nettoyage se fait uniquement à l'aide d'un torchon ou d'une serviette légèrement mouillée.
<i>HU</i>	A tisztítás kizárólag törölruha vagy enyhén nedvesített törölköző segítségével végezhető. Súroló hatású tisztítószereket nem szabad használni.
<i>I</i>	Pulire esclusivamente con un panno o un asciugamano umido.
<i>NL</i>	Reinig alleen met een stofdoek of een lichtjes vochtige doek. Gebruik geen schurende poetsmiddelen.
<i>RU</i>	Очищайте от пыли тряпкой или слегка влажной ветошью. Не допускается применение чистящих средств, не предназначенных для ухода за мебелью.
<i>RO</i>	Curățarea trebuie efectuată numai cu o cârpă sau cu un prosop ușor umezit. Nu utilizați agenți de curățare abrazivi.
<i>SK</i>	Čistení je nutné vykonávať výhradne pomoci utierky nebo ľahko zvlhnutým ručníkom. Nepoužívajte čistiaci prostriedky obsahujúci abrazívni častice.
<i>TR</i>	Lütfen sadece bir toz bezilye veya hafif nemli yumuşak bir bezle siliniz. Aşındırıcı temizlik malzemeleri kullanmayınız.







	
A	L
6	4

A
6

	8.0x30		3.0x13			4.0x30
B	D	G	H	S2	Q	H1
8	8	2	6	4	2	4

	8.0x30		4.0x30	
B	D	G	H1	S2
4	4	1	2	4

V-VII-IX-X-XIII

6.3x13				3.0x13			4.0x25
F	Z	X	I	H	S4	M	G
8	4	12	12	8	2	6	12

∅-10.0

KR
1



Uwaga • Upozornini • Achtung • Attention • Caution • Figyelem
Attenzione • Opgelet • Внимание • Atentie • Upozornenie • Dikkat



PL	<p>Załączony zestaw montażowy do zamocowania artykułu do ściany (kołki, wkręty, haki itp.) , przeznaczony jest wyłącznie do montażu artykułu na ścianach wykonanych z cegły lub betonu. Przy montażu artykułu na ścianie wykonanej z innych materiałów, należy zastosować odpowiednie do niej zamocowania. W razie wątpliwości prosimy zasięgnąć porady fachowca.</p> <p>Uwaga: Mocowanie mebla do ściany mogą przeprowadzić wyłącznie wykwalifikowane osoby, z uwagi na zastosowanie odpowiednio dopasowanych kołków do rodzaju ściany.</p>
CZ	<p>Přiložený materiál pro montáž na stěnu (hmoždinky a šrouby) je vhodný jen pro pevné zdivo (např. betonové nebo cihlové stěny) . Pro jiné skladby stěn budou případně nutné speciální hmoždinky a jiné šrouby. Poradte se případně s odborníkem.</p> <p>Pozor: Montáž nábytku na stěnu musí provést odborník, protože k montáži na stěnu jsou zapotřebí upravené hmoždinky.</p>
D	<p>Das beigefügte Wandbefestigungsmaterial (Dübel und Schrauben) eignet sich nur für festes Mauerwerk (z.B. Beton- oder Ziegelwände) . Für andere Wandaufbauten sind eventuell Spezialdübel und andere Schrauben notwendig. Ziehen Sie gegebenenfalls eine Fachkraft zurate.</p> <p>Achtung: Die Befestigung des Möbelstückes an der Wand muss von einer fachkundigen Person vorgenommen werden, da für die Montage an die Wand angepasste Dübel erforderlich sind.</p>
GB	<p>The enclosed wall mounting materials (dowels and screws) are only suitable for solid masonry (e. g. concrete or brick walls) . Special dowels and other screws may be necessary for other wall constructions. If necessary, please consult a qualified professional.</p> <p>Attention: A qualified professional is required when mounting furniture to the wall since dowels corresponding to the wall are required for this.</p>
F	<p>Le matériel de fixation murale fourni (chevilles et vis) convient uniquement à des murs solides (p. ex. murs en béton ou en briques) . Pour les autres constructions de murs, il faut éventuellement des chevilles spéciales et d'autres vis. Faites-vous conseiller par un spécialiste.</p> <p>Attention : La fixation du meuble contre le mur doit être effectuée par une personne compétente car, pour le montage mural, il faut utiliser des chevilles adaptées.</p>
HU	<p>A mellékelt fali rögzítőkészlet (tipli és csavarok) csak tömött falazatban (pl. betonfalban, téglafalban) használható. Más faltípusokhoz speciális tiplire és csavarra lesz szükség. Szükség esetén kérje ki egy szakember véleményét</p> <p>Figyelem: A bútorelemek falra rögzítését szakembernek kell végeznie, mert a rögzítéshez megfelelő tiplit kell használni.</p>
I	<p>I materiali di fissaggio allegati (tasselli e viti) sono adatti solo ai muri compatti (ad es. di calcestruzzo o mattoni) . Per altri tipi di pareti è probabile che occorrono tasselli speciali e altre tipologie di viti. Richiedere eventualmente il consiglio di un esperto.</p> <p>Attenzione: Il fissaggio del mobile alla parete deve essere eseguito da persone esperte, dato che occorrono tasselli adeguati</p>
NL	<p>Het bijgeleverde bevestigingsmateriaal (pluggen en schroeven) is geschikt voor vaste muren (bijv. betonnen of bakstenen muren) . Voor andere muurconstructies zijn eventueel speciale pluggen en andere schroeven noodzakelijk. Consulteer eventueel een vakman</p> <p>Opgelet: een vakkundige persoon dient het meubelstuk aan de muur te bevestigen; voor de montage aan de muur zijn immers aangepaste pluggen vereist.</p>
RU	<p>Входящий в комплект поставки материал для крепления на стене (дюбели и болты) предназначен только для прочных каменных стен (например, бетонных или кирпичных). Для других типов стен используйте по мере необходимости специальные дюбели и другие болты. По мере необходимости обратитесь за помощью к специалистам.</p> <p>Внимание: Поскольку для монтажа на стене необходимо использовать специальные дюбели, мебель должна быть закреплена на стене квалифицированным персоналом.</p>
RO	<p>Materialul furnizat pentru montajul de perete (dibluri și șuruburi) este adecvat numai pentru zidărie solidă (de exemplu pereți din beton sau din cărămidă) . Pentru alte structuri de pereți, este posibil să fie necesare dibluri speciale, precum și alte șuruburi. Dacă este necesar, consultați un specialist.</p> <p>Atenție: Fixarea la perete a piesei de mobilier se realizează numai de către personal competent, deoarece montajul de perete necesită dibluri adecvate.</p>
SK	<p>Priložený materiál pre upevnenie na stenu (hmoždinky a skrutky) je vhodný len pre pevné murivo (napr. betónové alebo tehlové steny) . Pre iné steny sú potrebné príp. špeciálne hmoždinky a iné skrutky. V prípade potreby sa poradte s odborníkom.</p> <p>Pozor: Upevnenie nábytku na stenu musí vykonať odborník, nakoľko sú pre montáž na stenu potrebné vhodné hmoždinky.</p>
TR	<p>Teslimat kapsamındaki duvar tipi sabitleme materyali (dübel ve vidalar) sadece beton ve tuğla duvarları gibi sağlam duvar yapıları için uygundur. Başka duvar yapıları için özel dübeller veya başka vidalar gerekli olabilir. Gerekirse bir uzmandan yardım alınız.</p> <p>Dikkat: Mobilya parçasının duvara sabitlenmesi, duvar montajı için özel uyarlanmış dübeller gerektirdiğinden bu iş sadece bu konuda uzman bir kişi tarafından gerçekleştirilmelidir.</p>

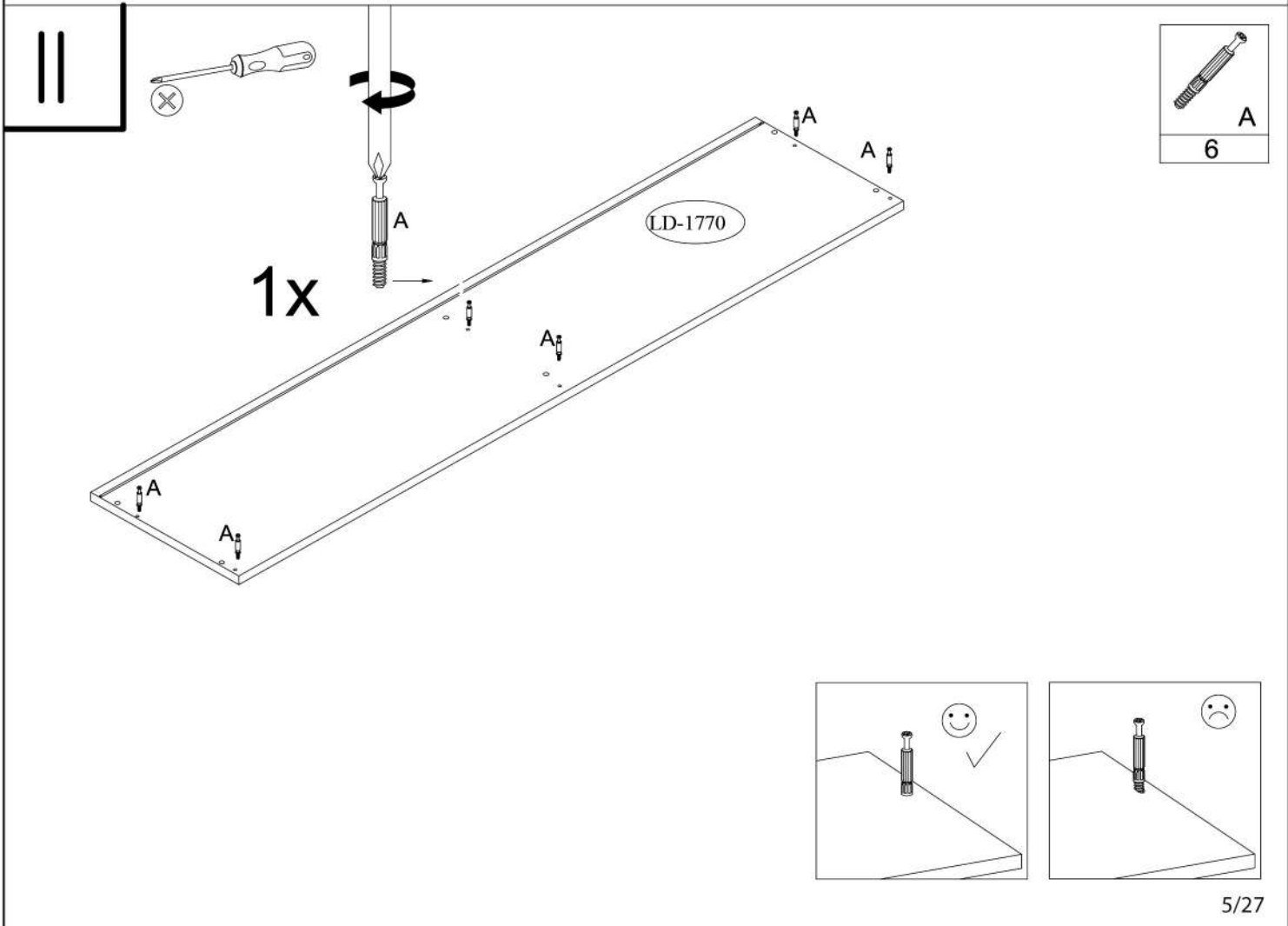
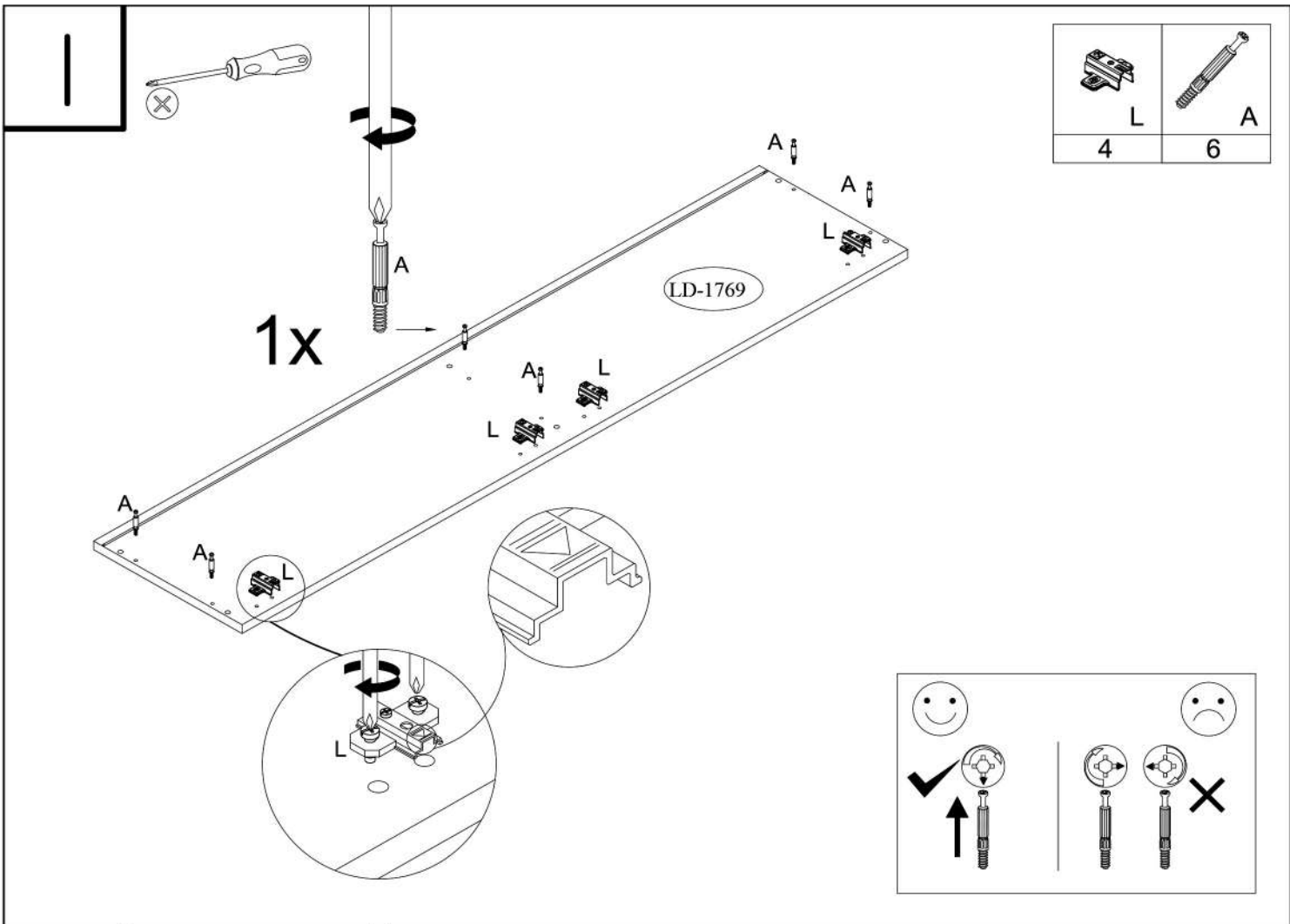

III

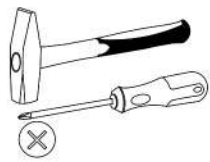

	3.0x13 H		4.0x30 H1	8.0x30 D	
S2	H	G	H1	D	B
4	6	2	4	8	8

1x

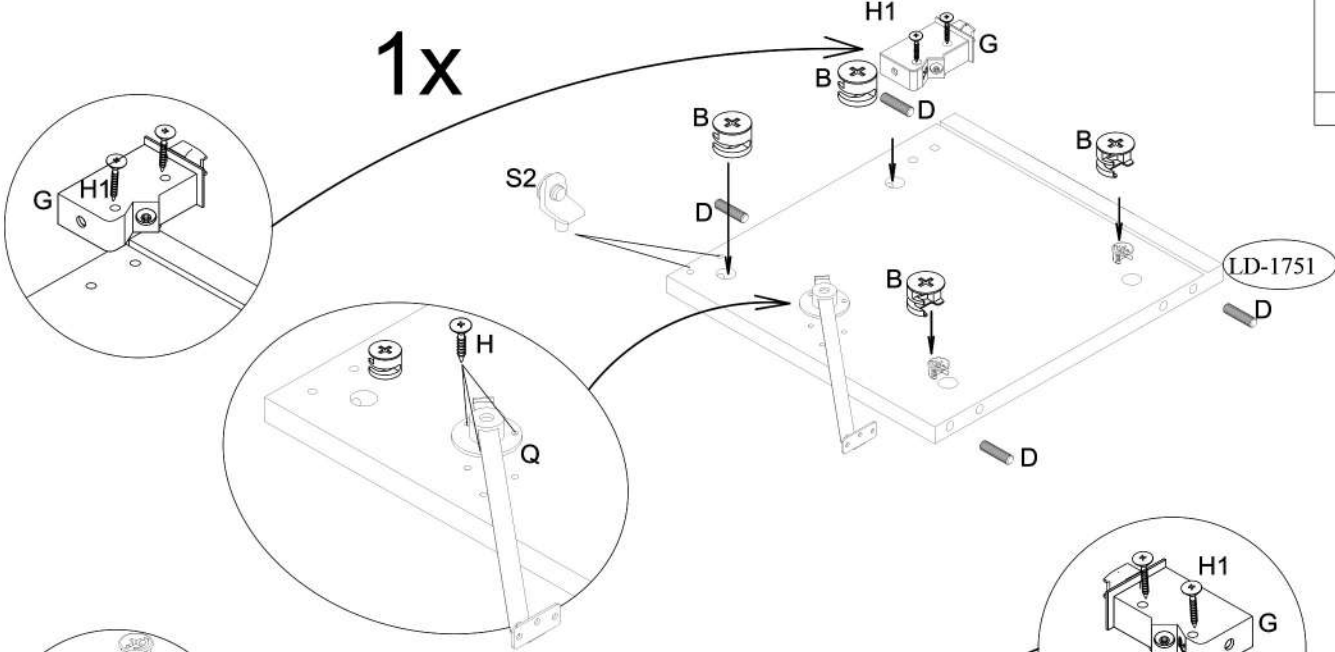

Q
2

1x

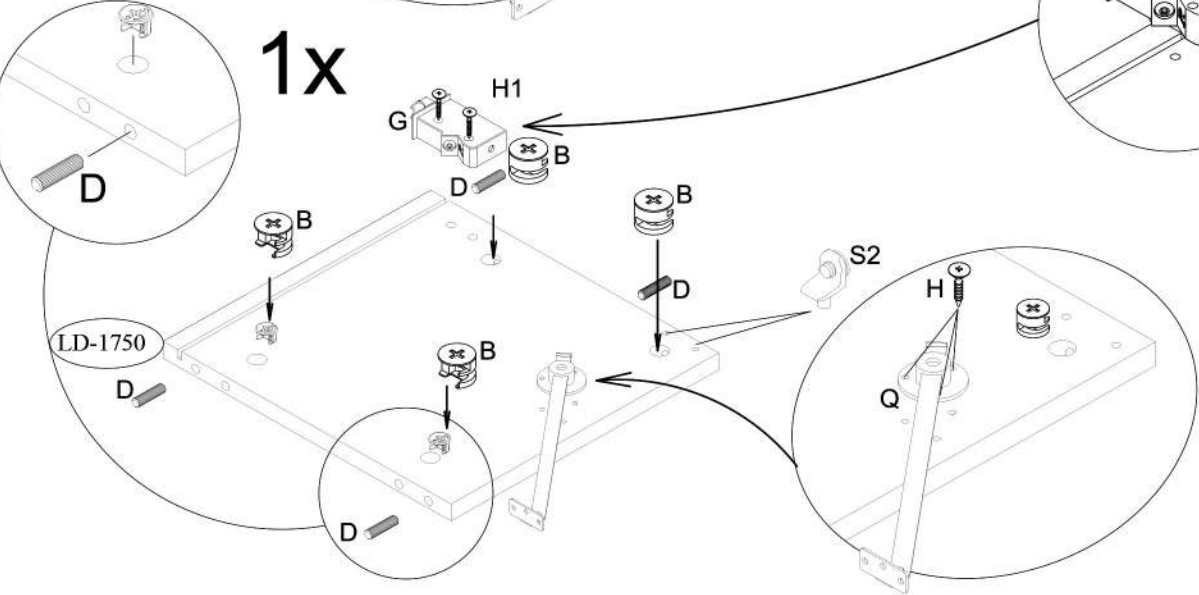

IV

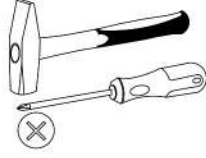

		4.0x30 H1	8.0x30 D	
S2	G	H1	D	B
4	1	2	4	4

1x

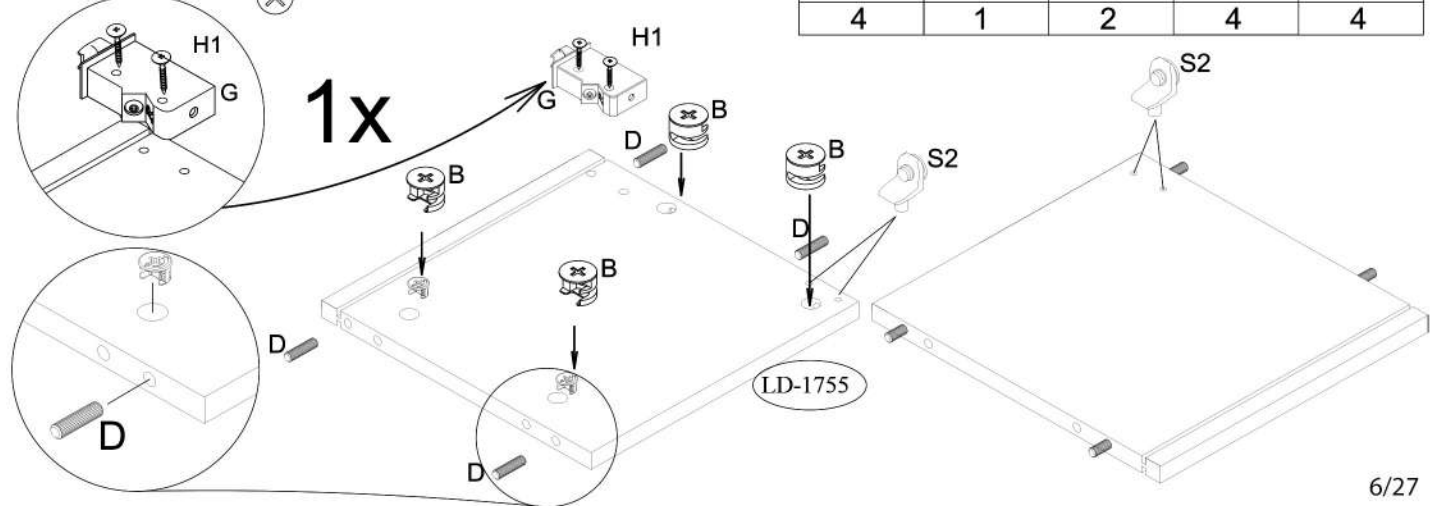

V

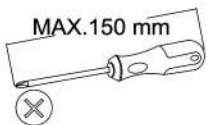

6.3X13		F	Z
8			4

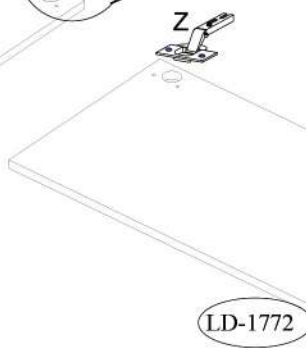
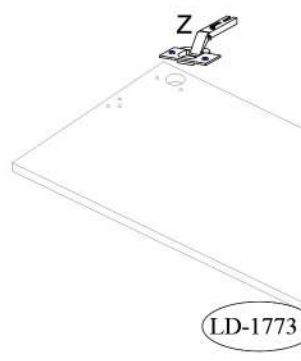
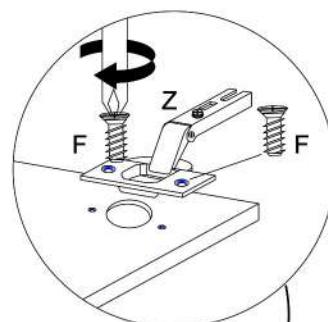
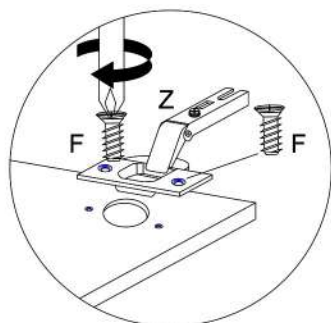

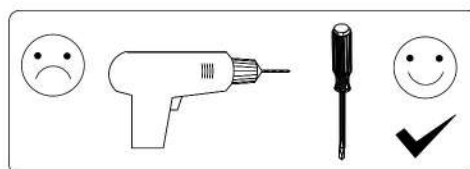
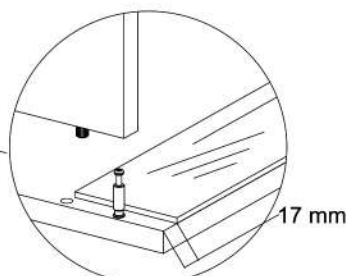
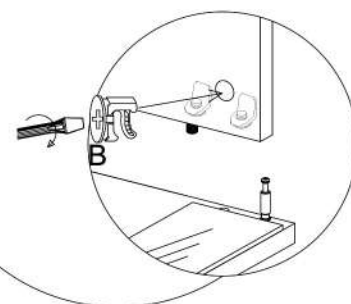
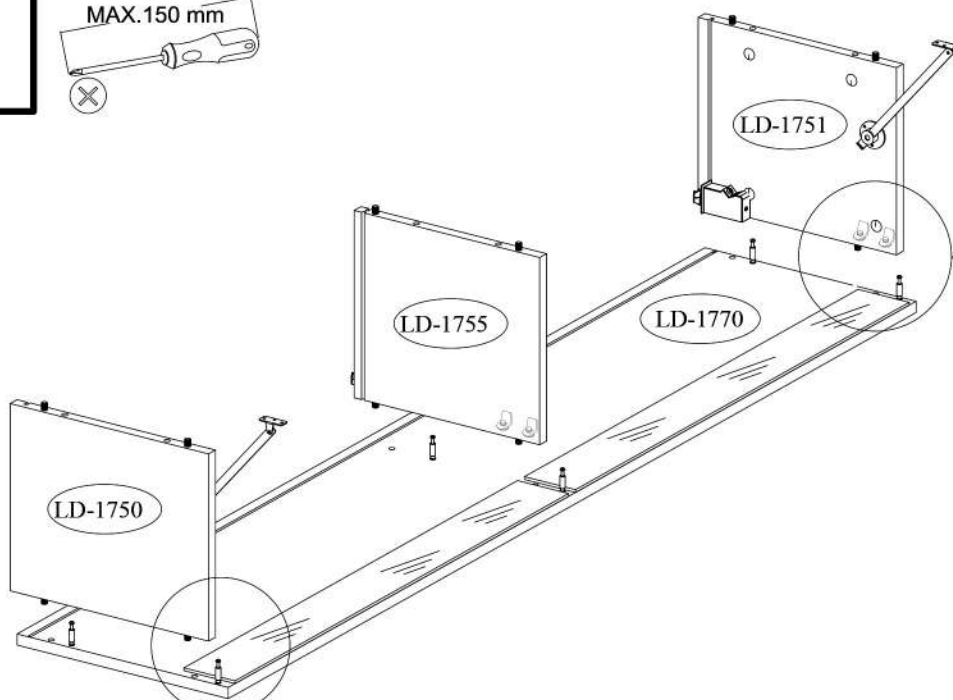

VI

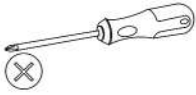

VII



3.0x13 	
H	S4
2	2

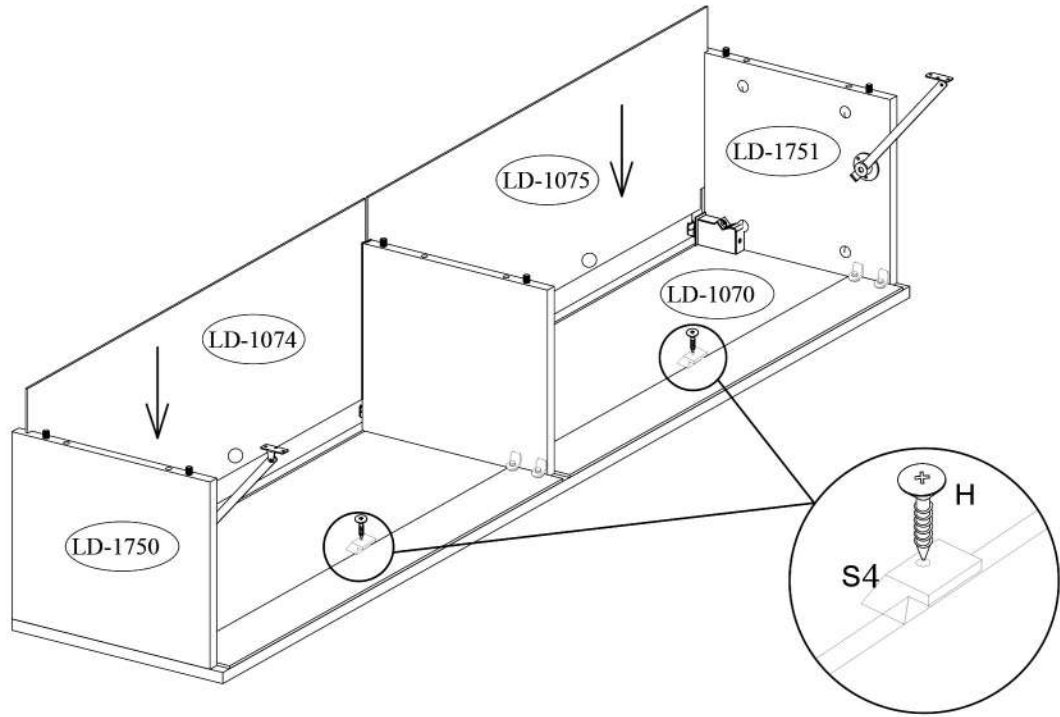

VIII

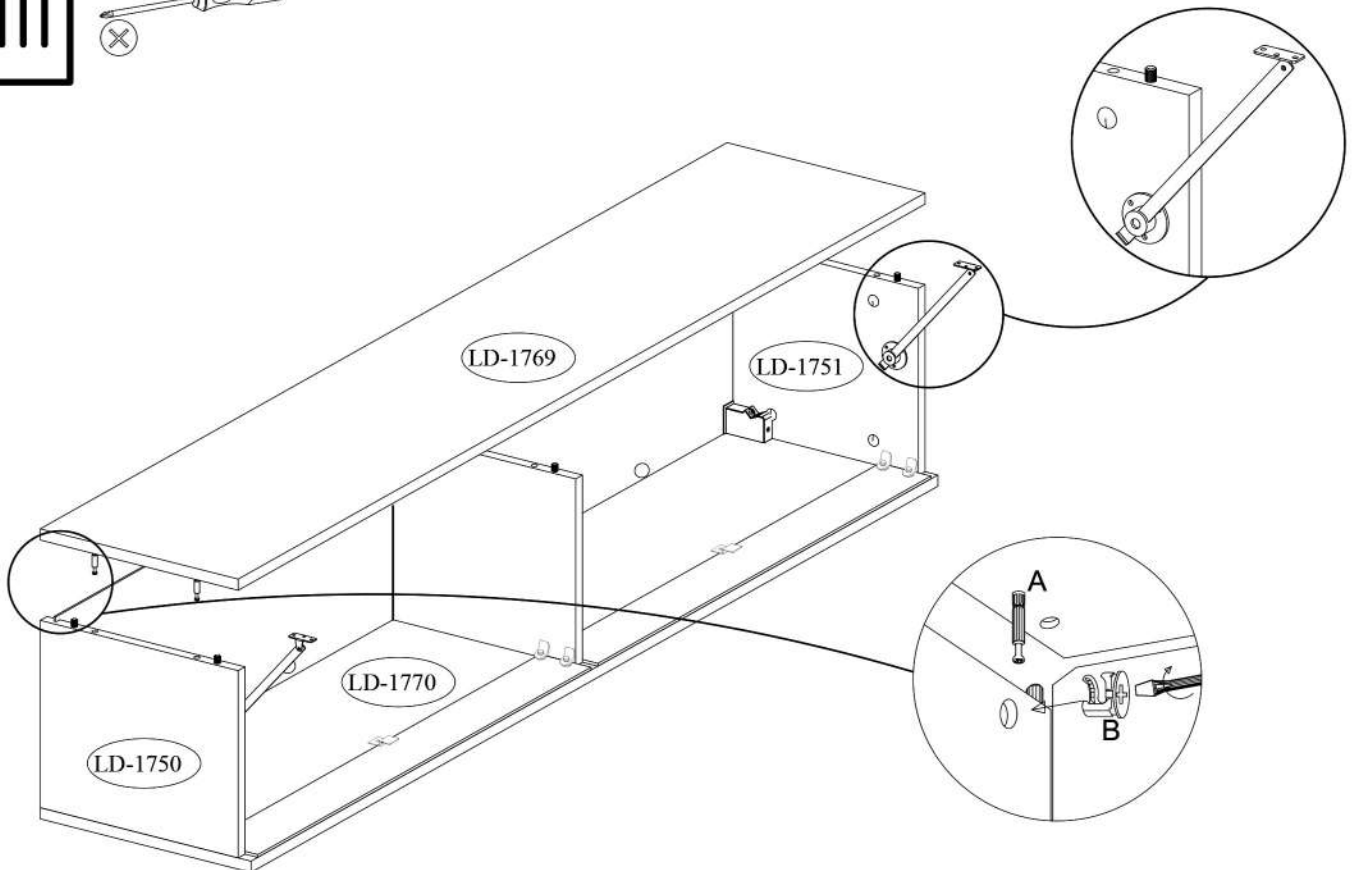
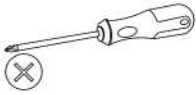

IX

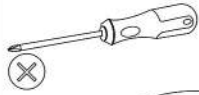

3.0x13	
H	
6	X
6	12

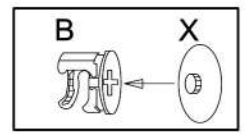
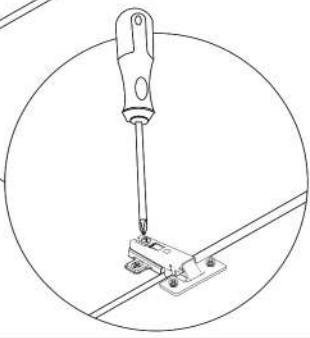
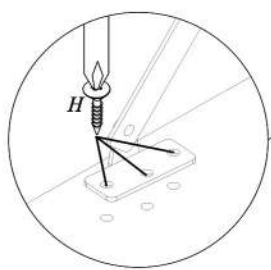
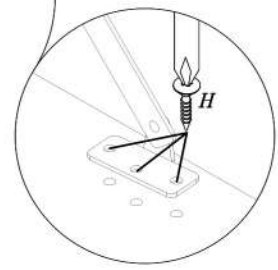
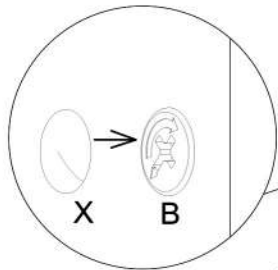
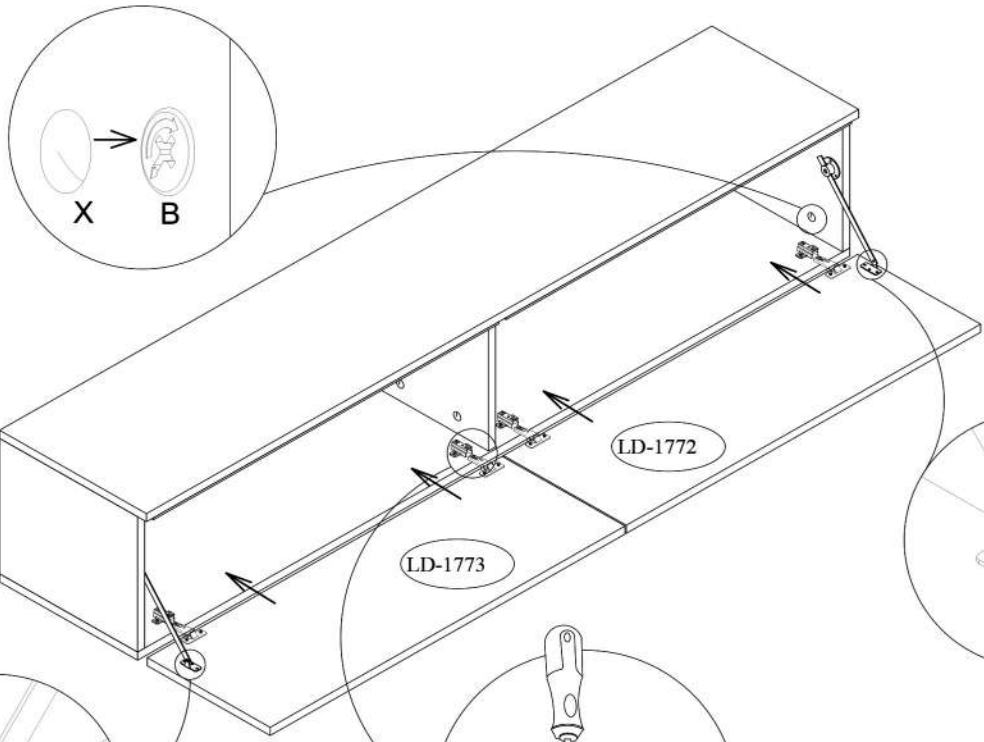

X



12

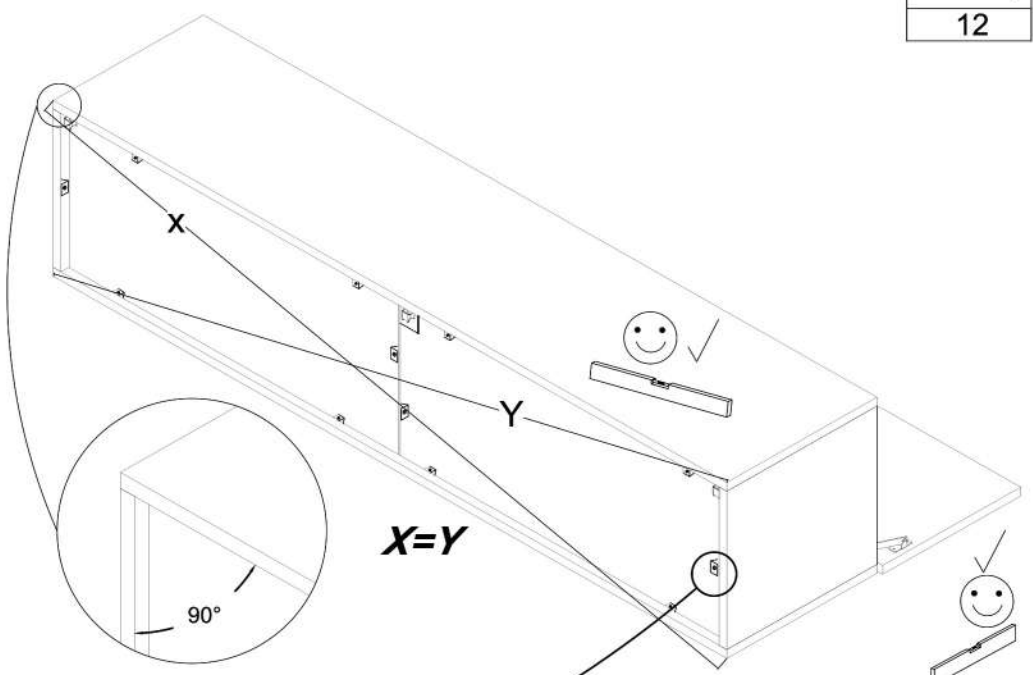
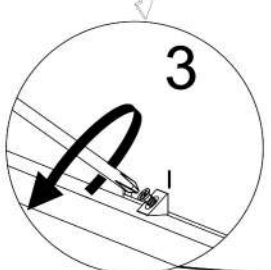
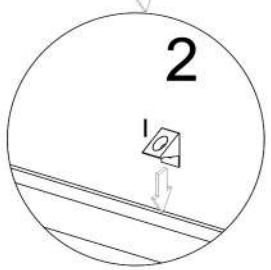

XI

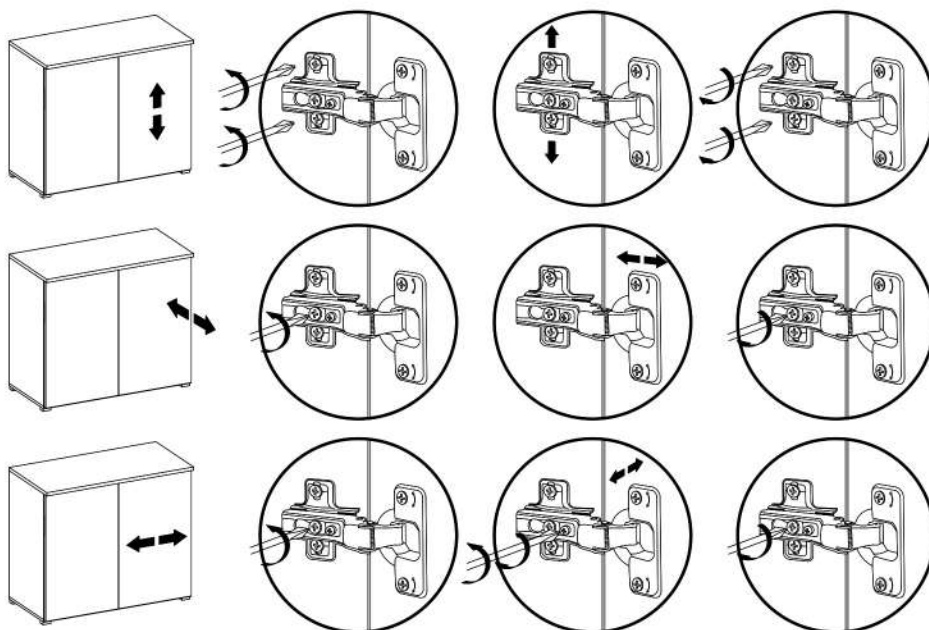
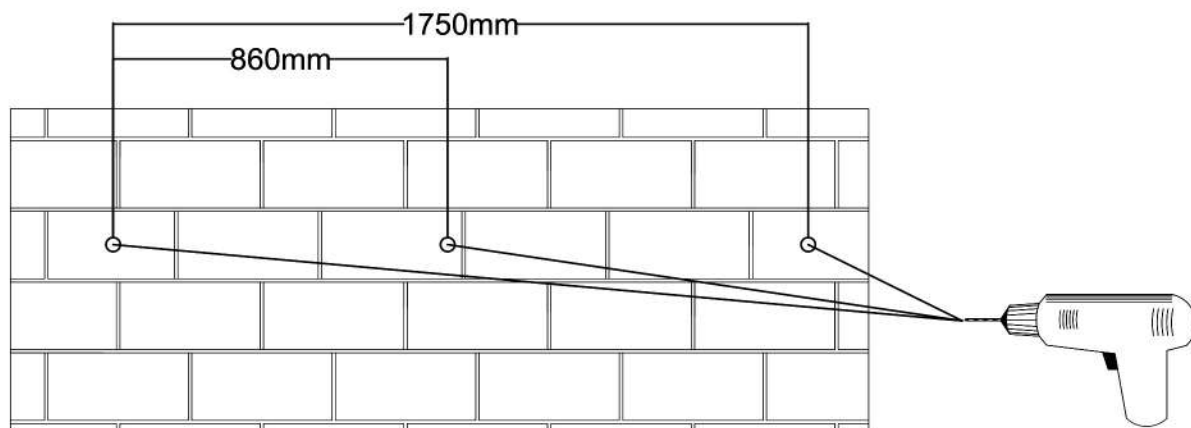

- (F) Mettre la porte (égaliser les gonds)
- (I) Regolare la porta (livellare le parentesi)
- (D) Turen einstellen (Scharniere justieren)
- (GB) Adjusting the doors (adjusting the hinges)
- (NL) Deuren instellen (scharnieren afstellen)
- (PL) Nastawic drzwi (wyrównac zawiasy)
- (TR) Kapıların ayarlanması (mentesçelerin seviye ayarı)
- (RU) Регулировка дверей (регулировка шарнира)
- (RO) Ajustați ușa (aliniati balamalele)
- (CZ) Seřid'te dveře (vyrovnejte závěsy)
- (SK) Zrad'te dvere (vyravnajte závesy)
- (HU) Állítsa be az ajtó (igazítsa be a zsanérokot)

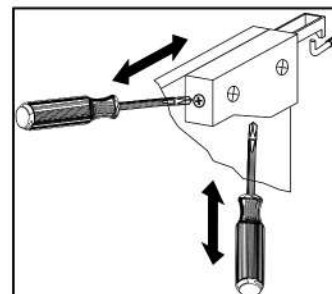

- (PL)** Uwaga: Punkty mocowania opcjonalnego oświetlenia
- (CZ)** Upozornění: body k připevnění doplňkového osvětlení
- (D)** Hinweis: Befestigungspunkte für optionale Beleuchtung
- (GB)** N.B.: Fixing points for optional lighting
- (F)** Remarque: Points de fixation de l'éclairage optionnel
- (HU)** Figyelem: Opcionális világítás rögzítési pontjai
- (I)** NOTA: punti di fissaggio opzionale dell'illuminazione
- (NL)** OPGELET: Optionele bevestigingspunten van de verlichting.
- (RU)** ВНИМАНИЕ: Точки крепления дополнительного освещения
- (RO)** Atenție: Punctele opționale de fixare a iluminatului
- (SK)** Upozornenie: body k pripevnení dodatočného osvetlení
- (TR)** Dikkat: Seçenekli aydınlatmanın yerleştirilmesinin noktaları

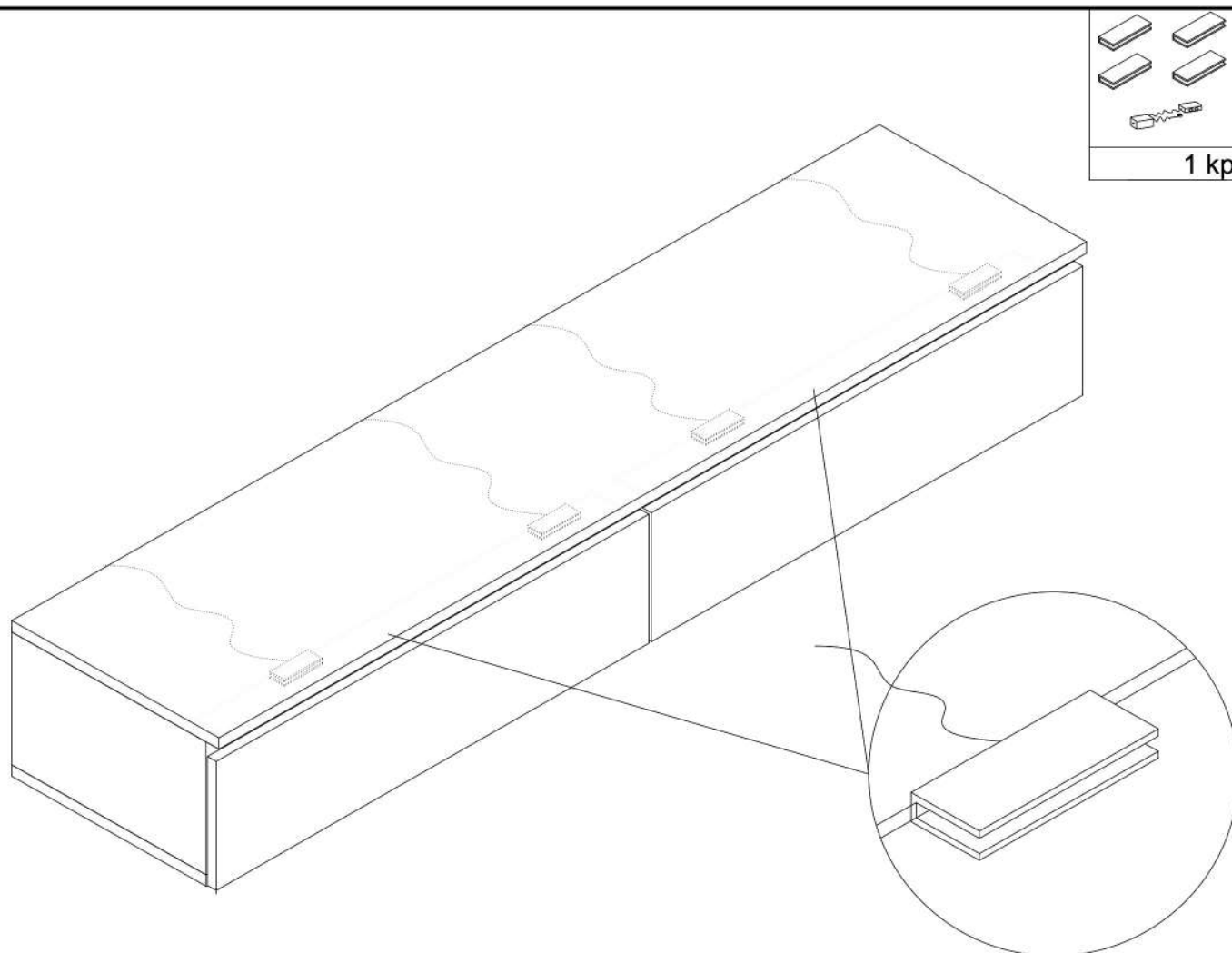

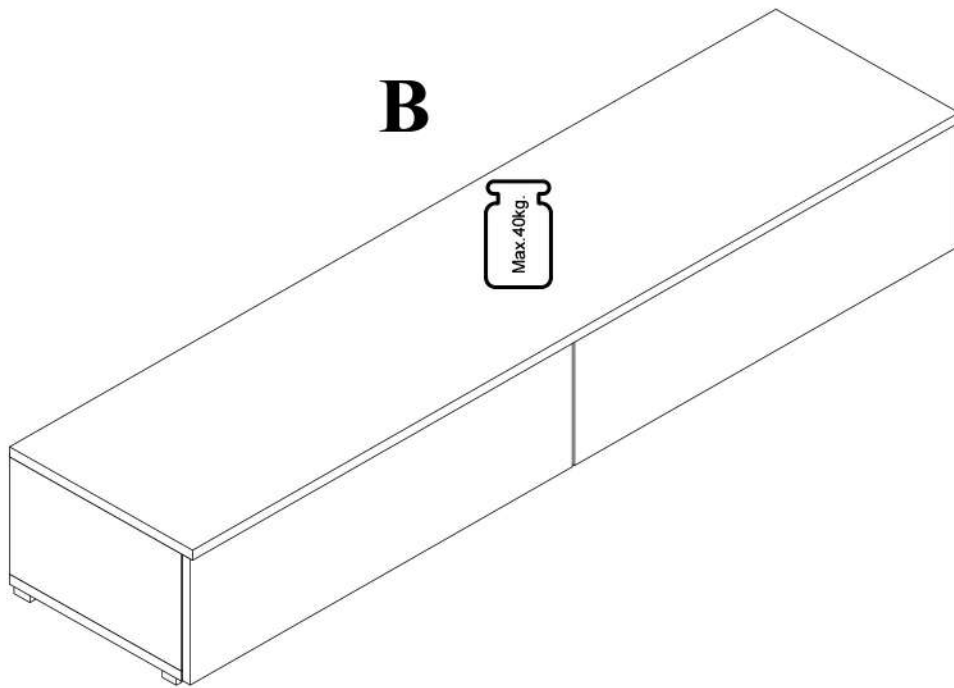

XII



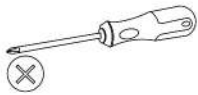



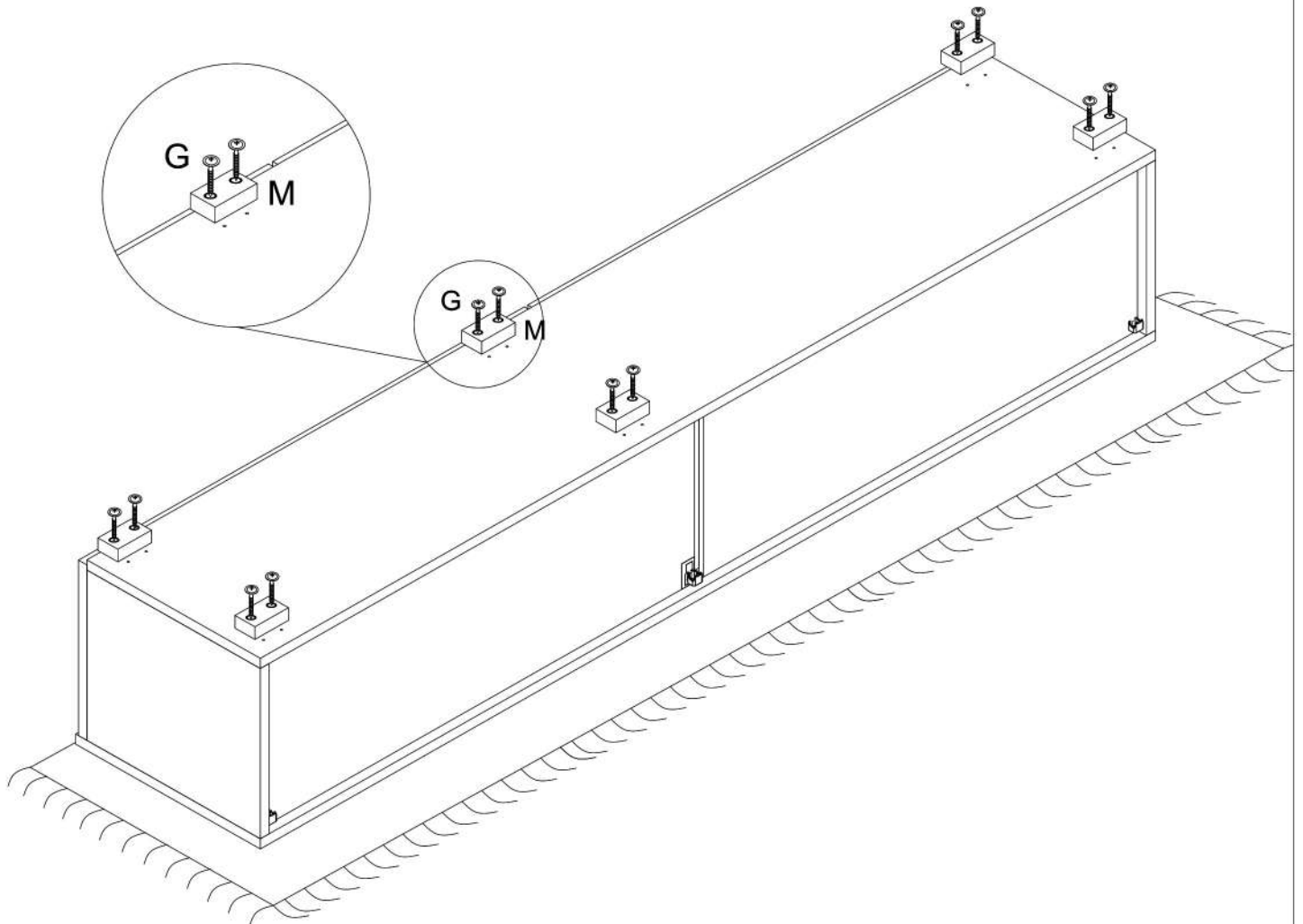

XIII

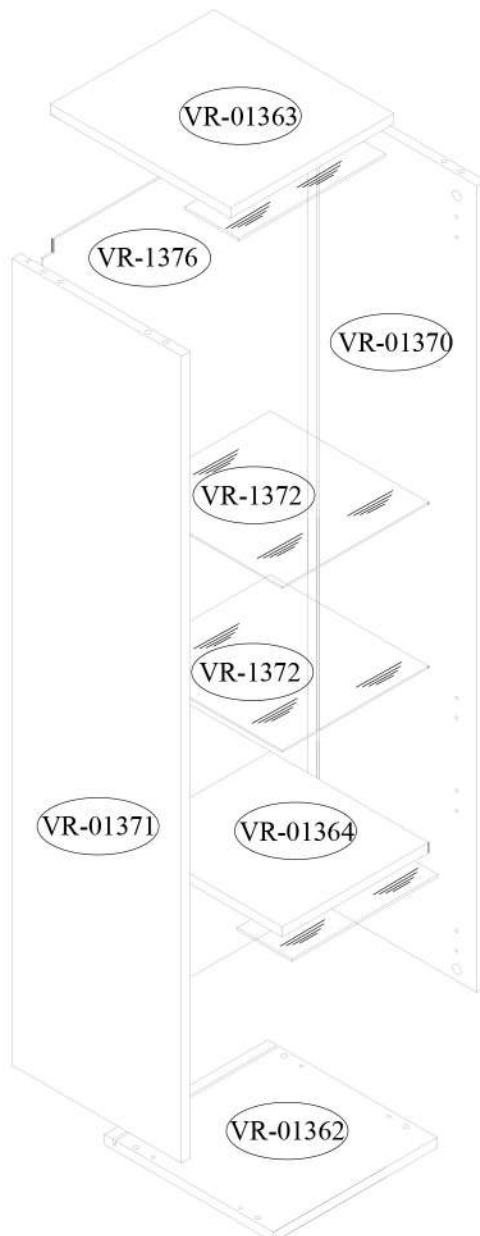
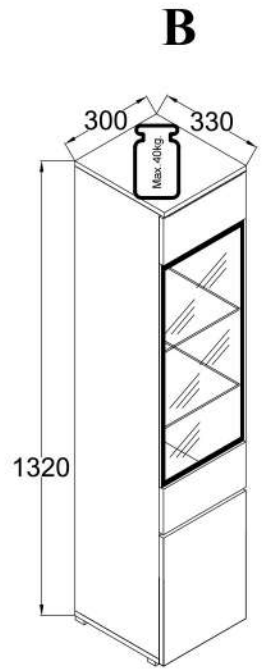
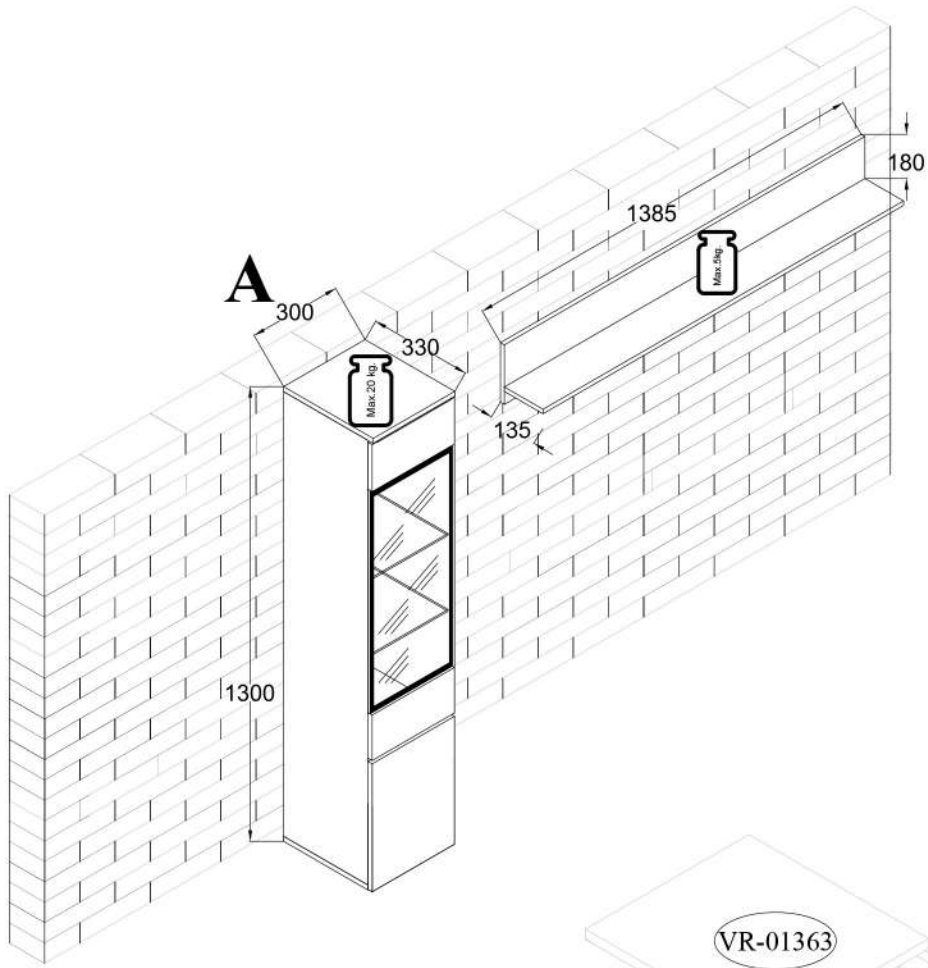



	4.0x25 
M	G
6	12















 A	 S3	 G	4.0x30  H1	8.0x30  D	 B
4	16	2	4	8	8

 A
8







 B	8.0x30  D
4	4

6.3X13  F	 Z
8	4

VII - VIII - X - XI

 X	 I	3.0x13  H	 S4	 M	4.0x25  G	 L	 MS	∅-10.0  KR
8	8	2	2	4	8	4	1	1

XII - XV

 O	 Q	 Y1	8.0x30  D	3.0x13  H1	 BP	∅-10.0  KR
5	1	2	4	4	2	1

1

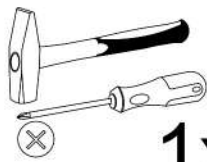

1x

			4.0x30 	8.0x30 	
A	S3	G	H1	D	B
4	16	2	4	8	8

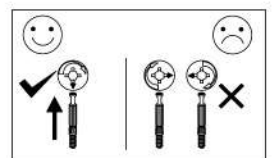
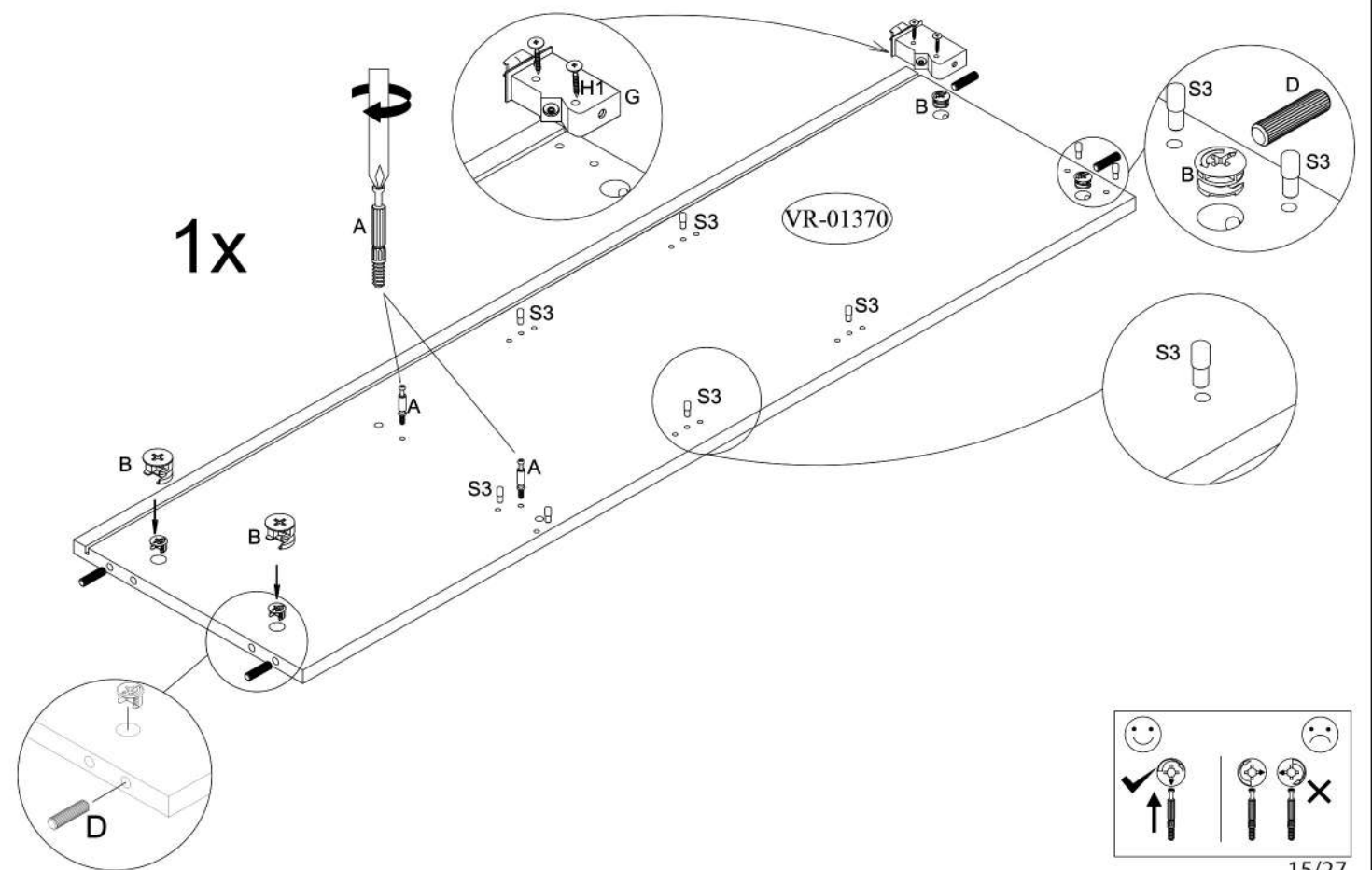
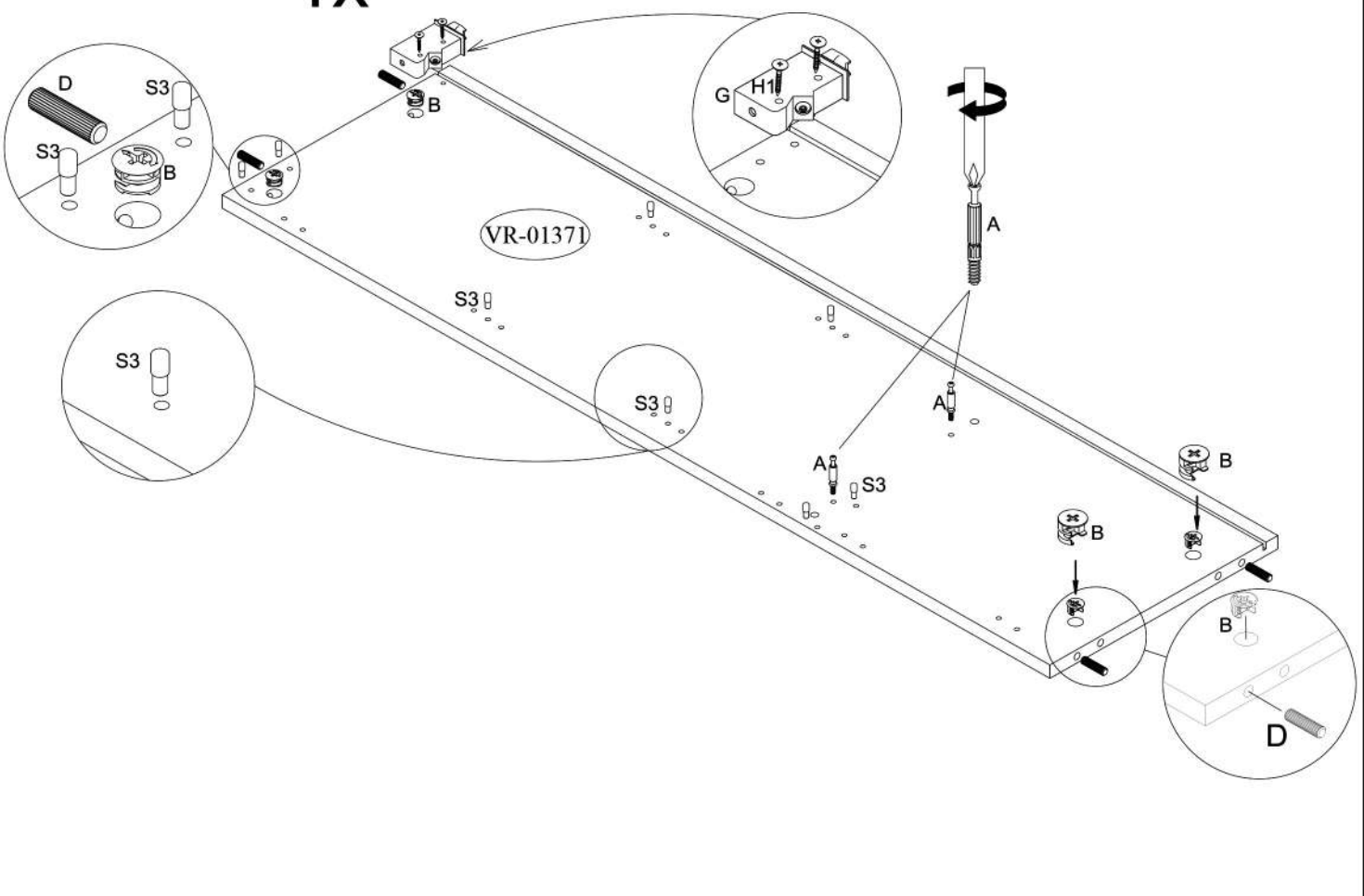

II

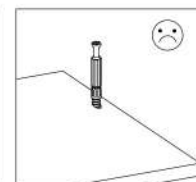
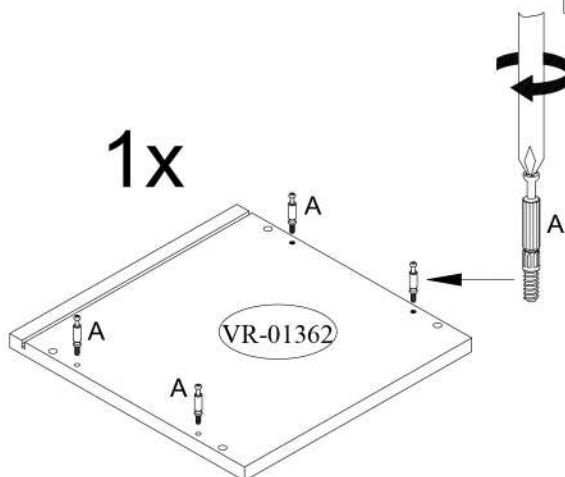
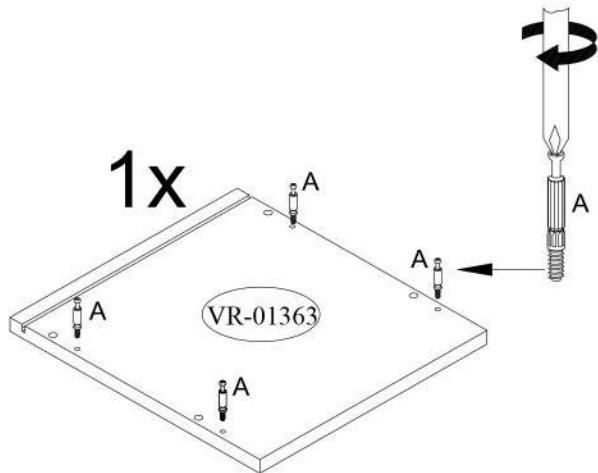
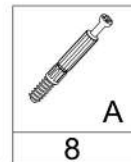

III

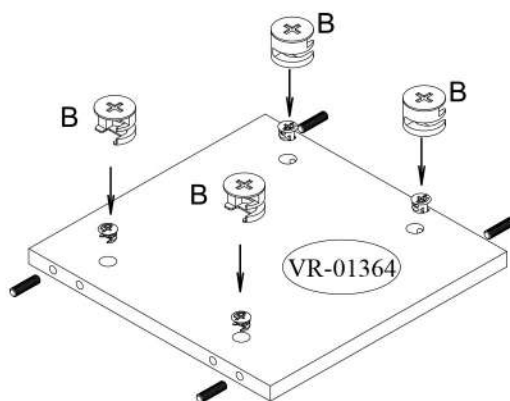
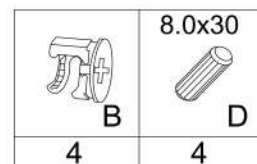

IV

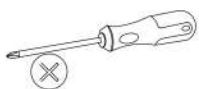

6.3X13		
	F	Z
8		4

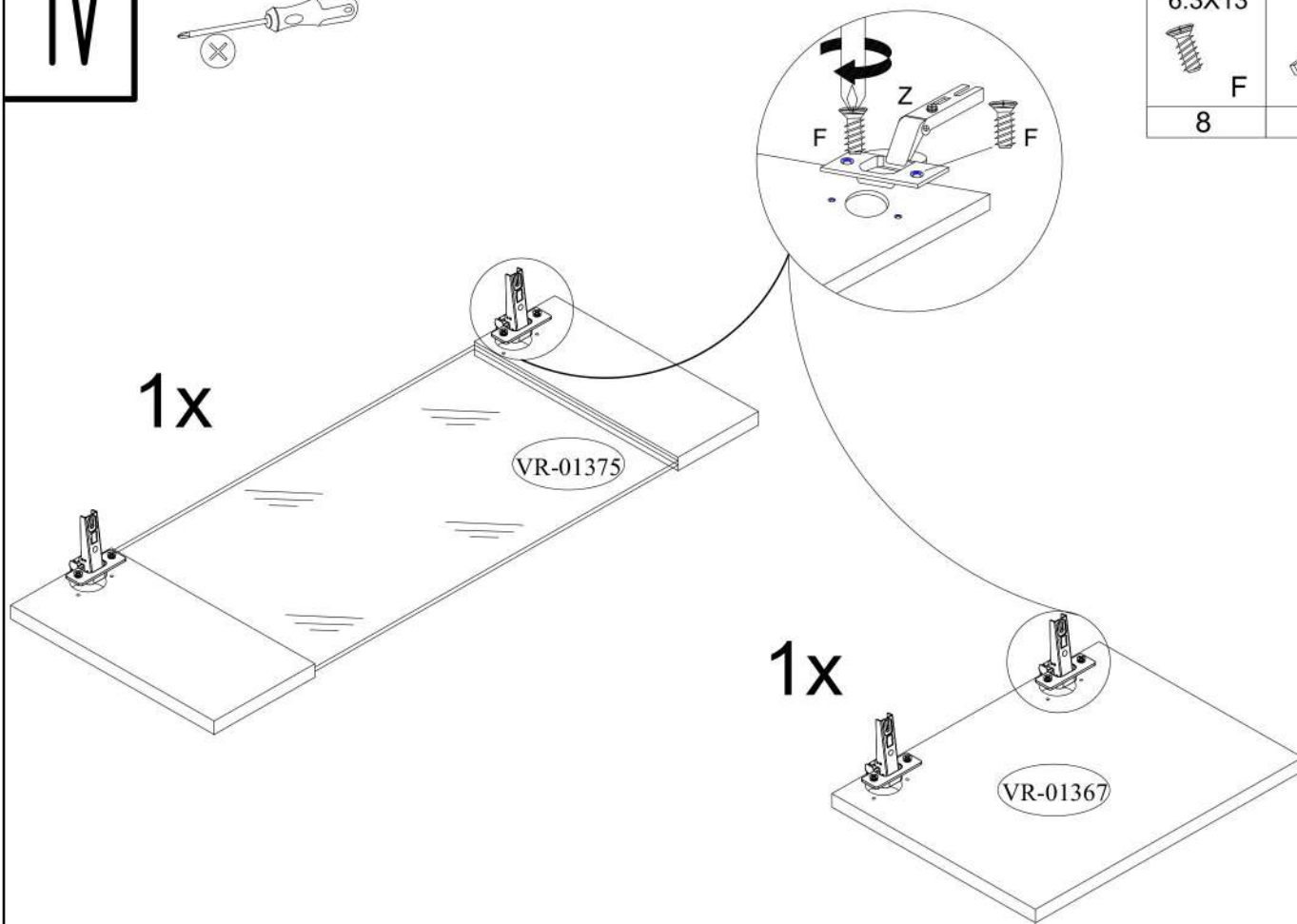

V

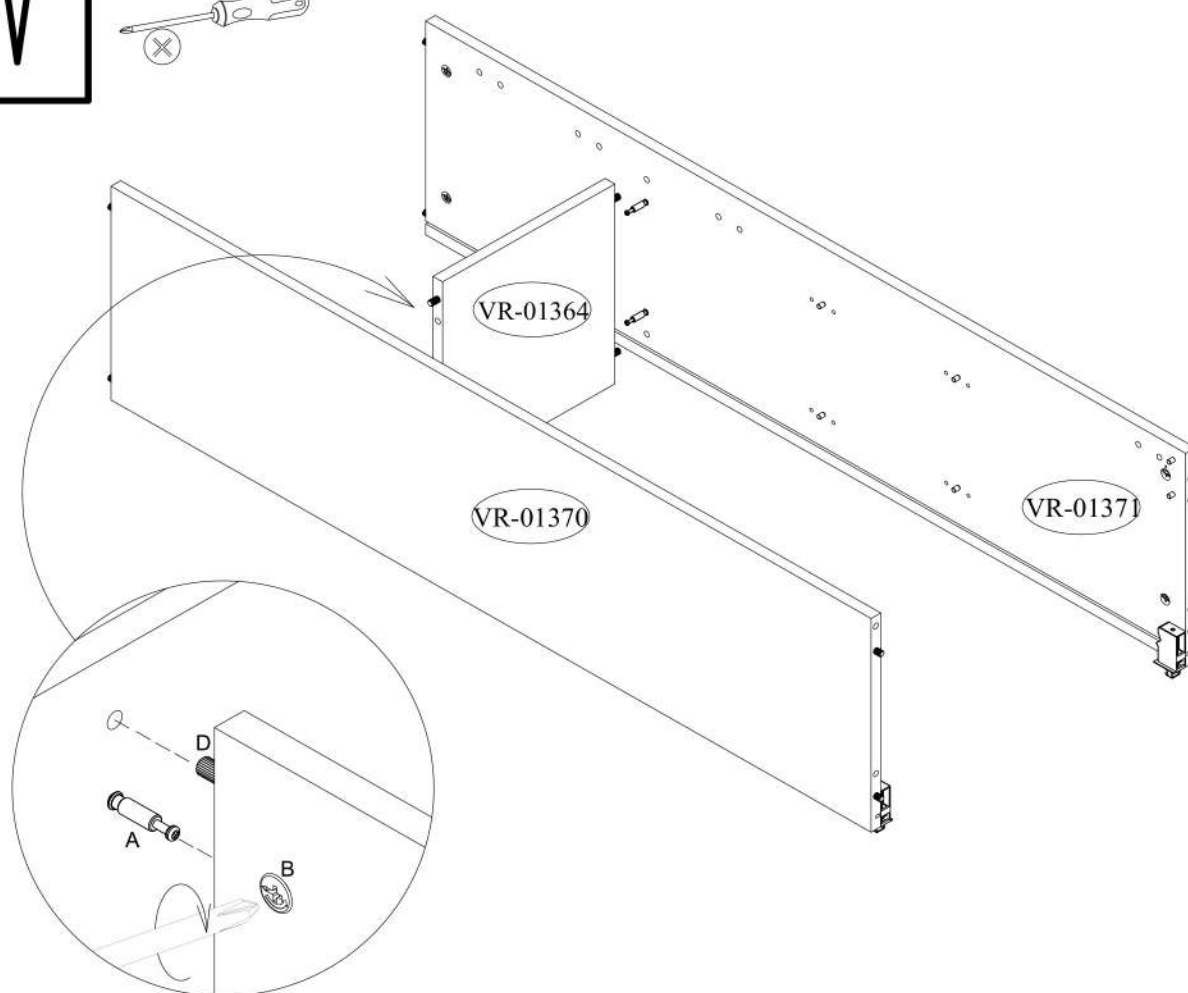
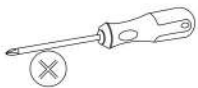

VI

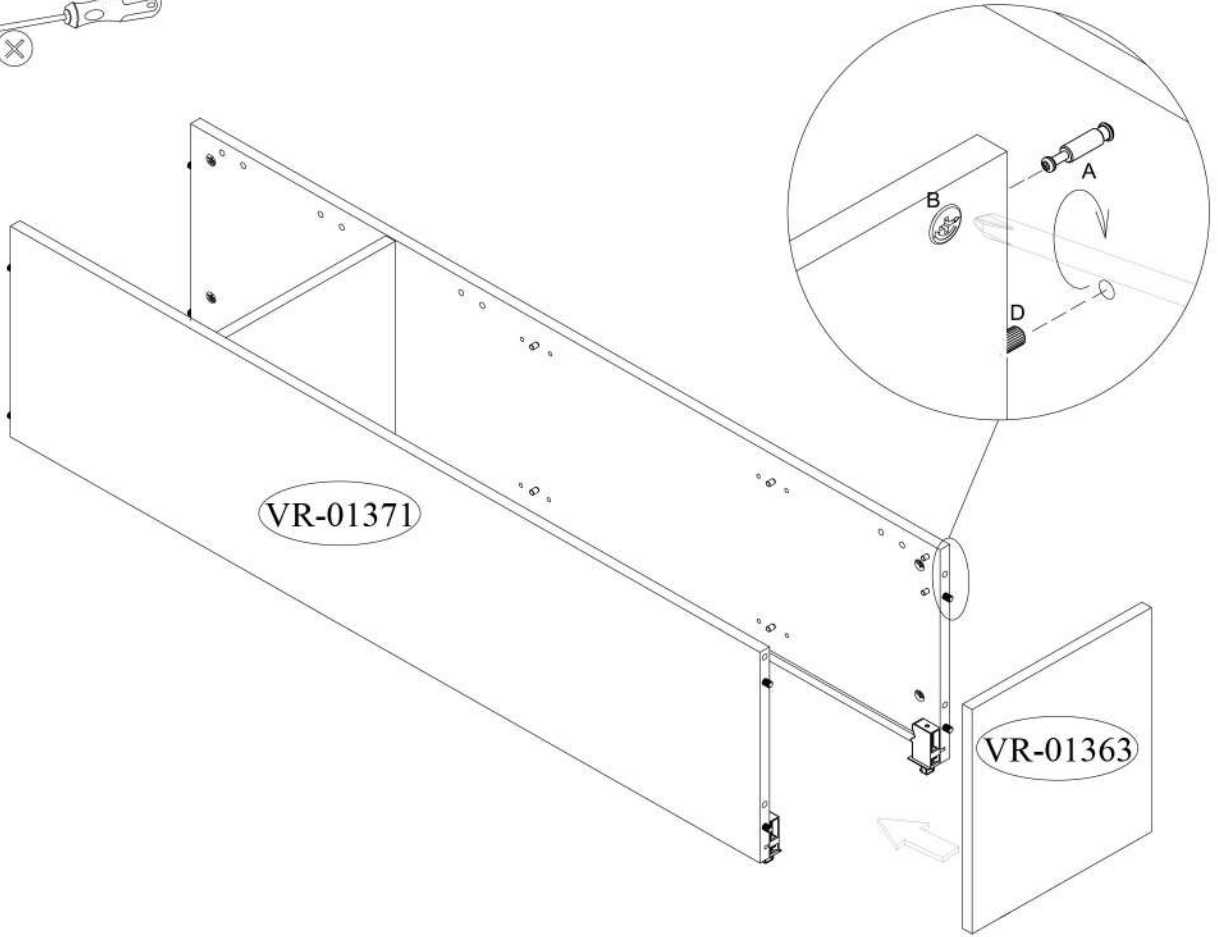
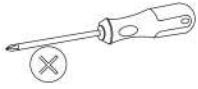

VII

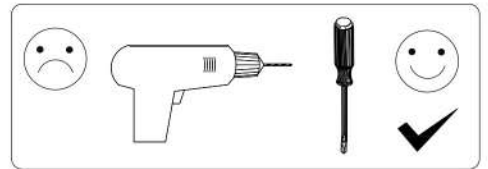
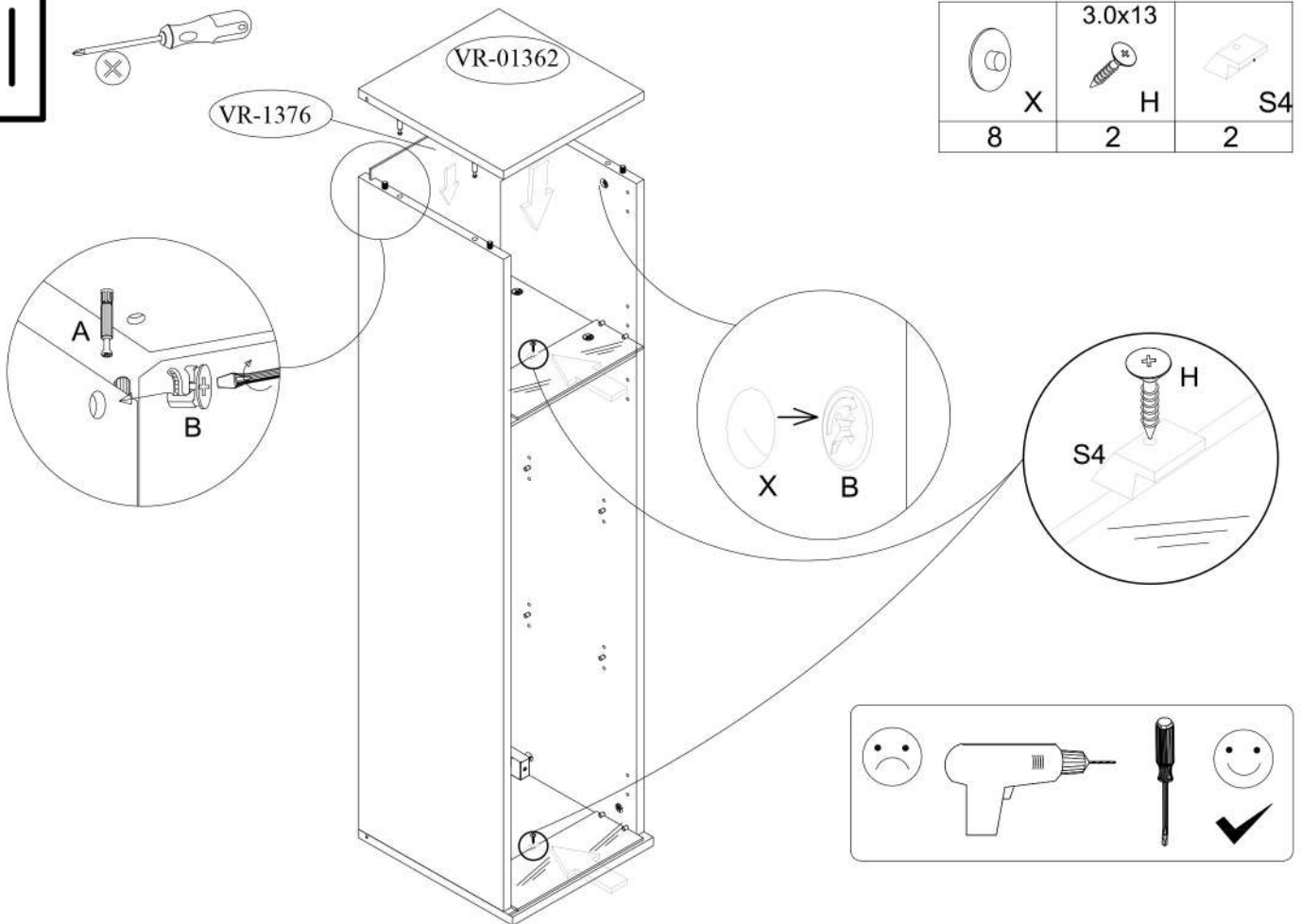
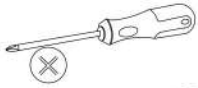

VIII

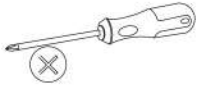

R

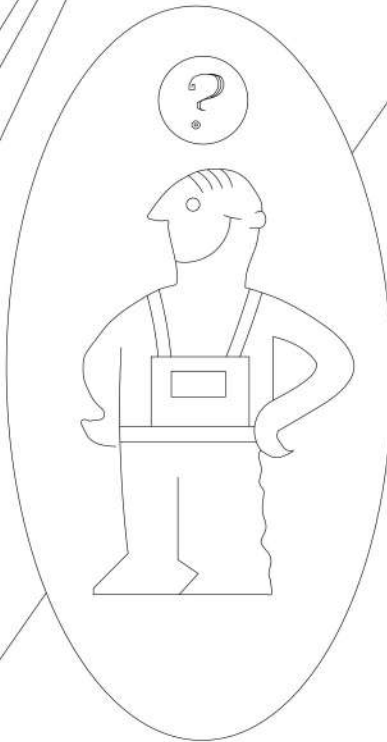
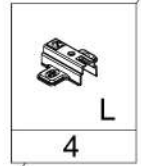
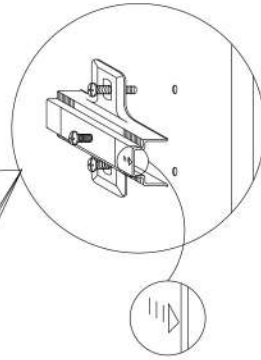
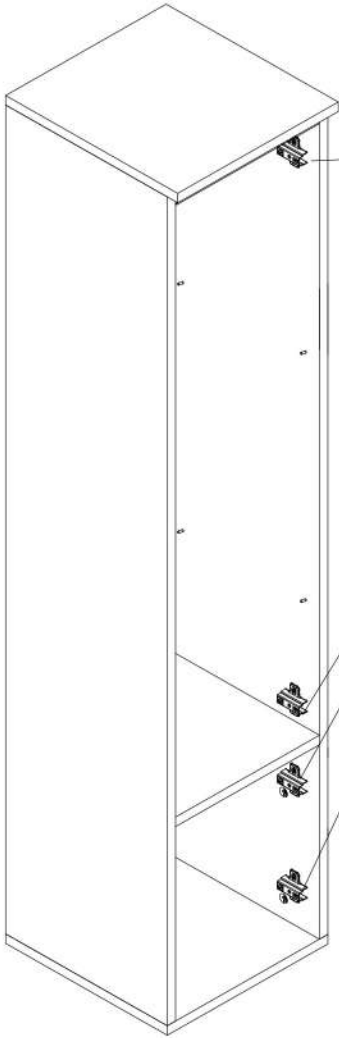

L

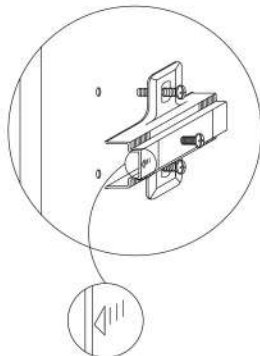
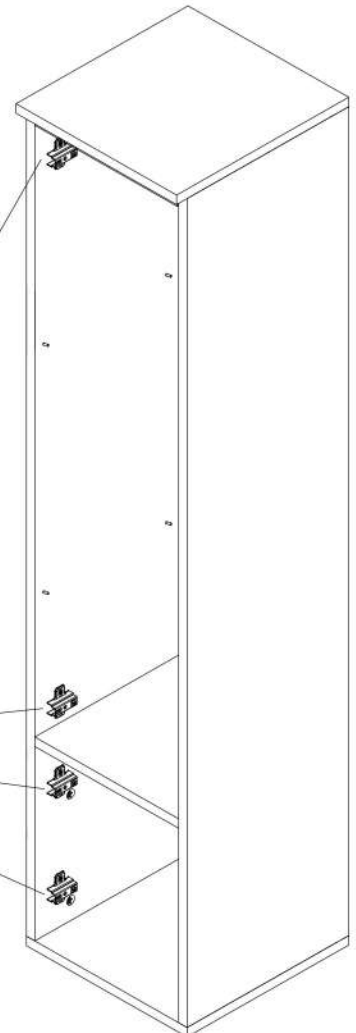

IX

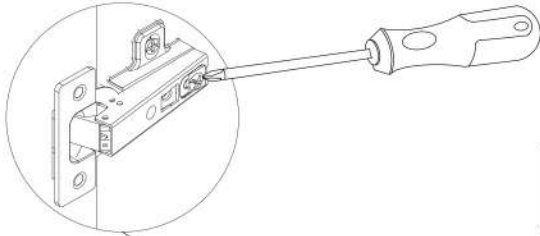
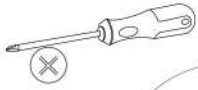

VR-01375

VR-01367

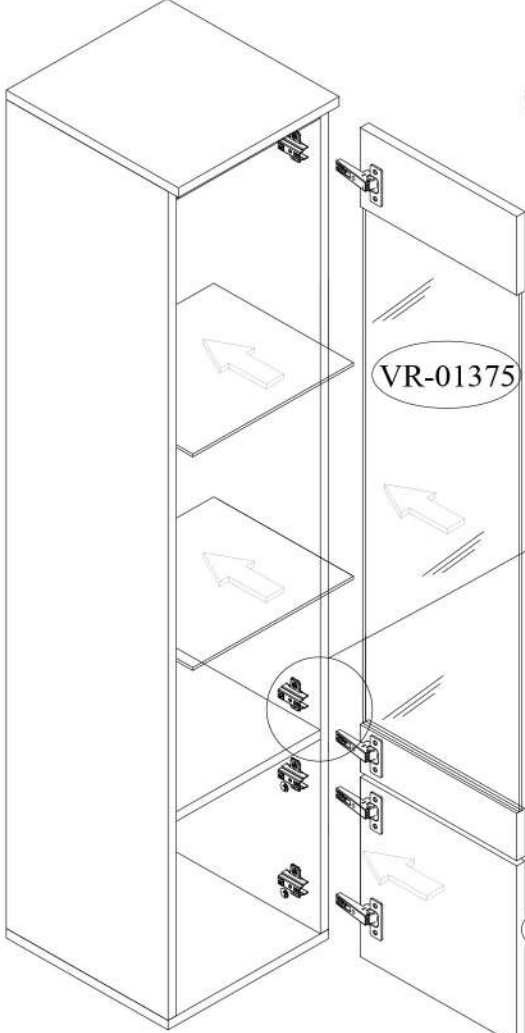
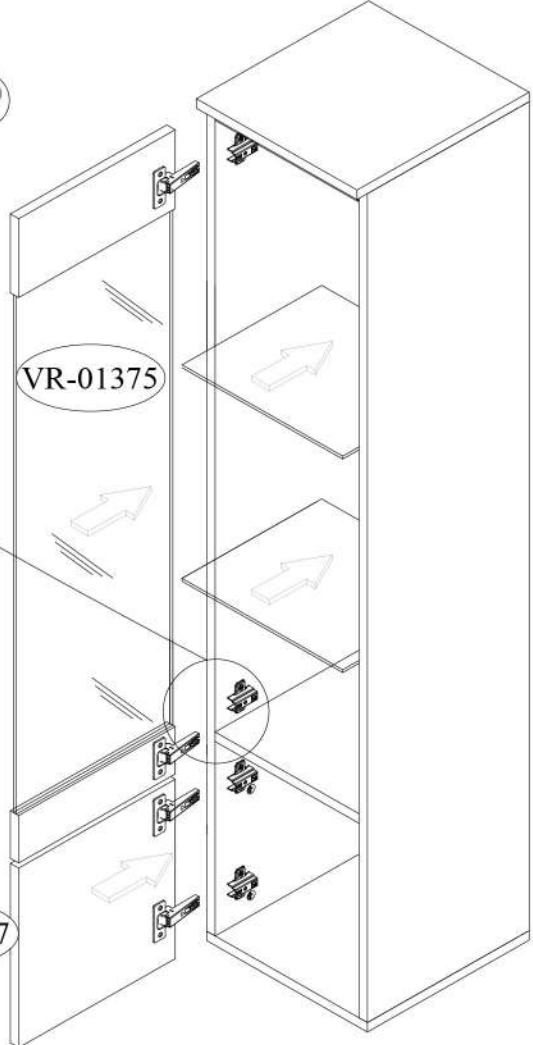

VR-01375

VR-01367

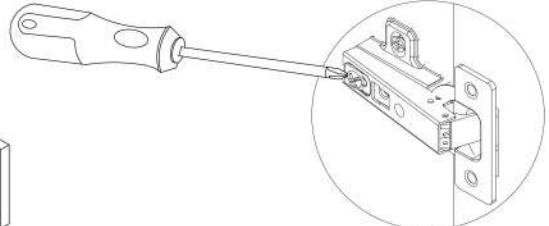

X

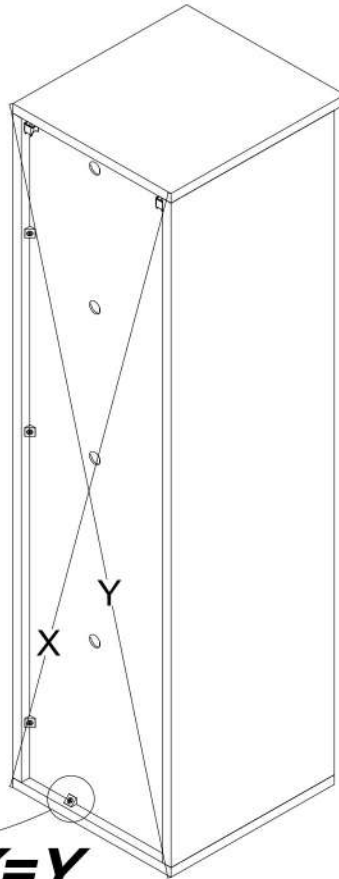
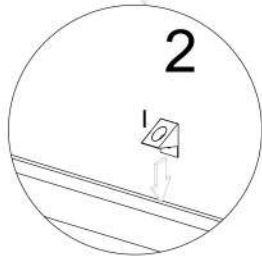
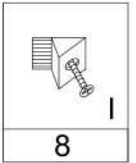
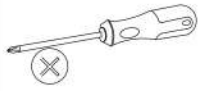

X=Y

XI

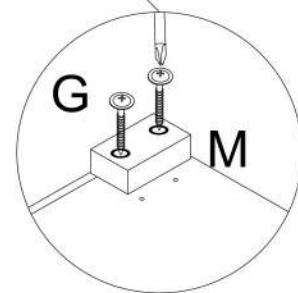
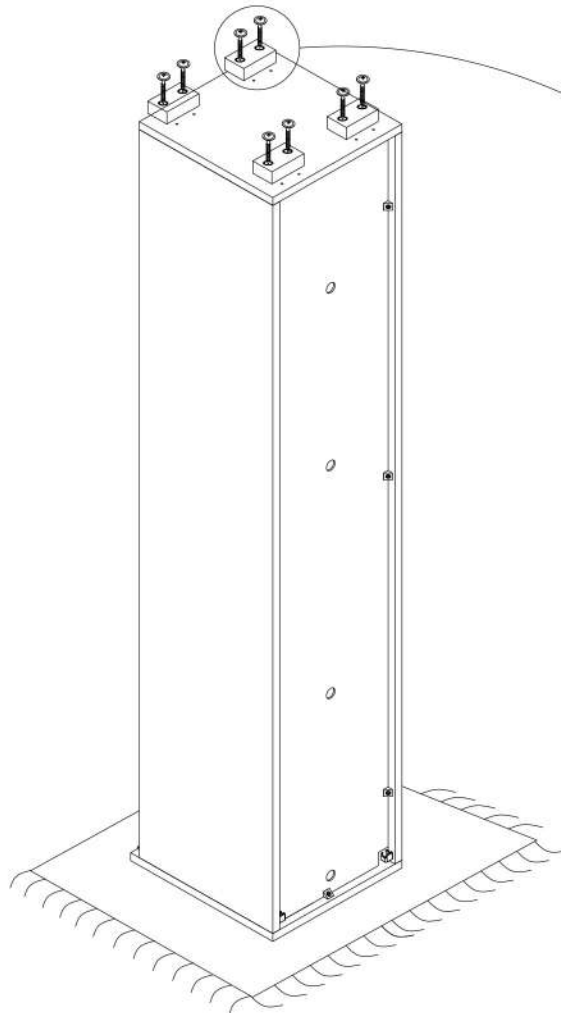
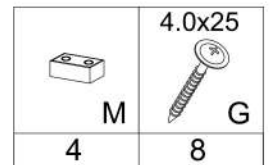
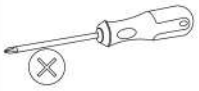

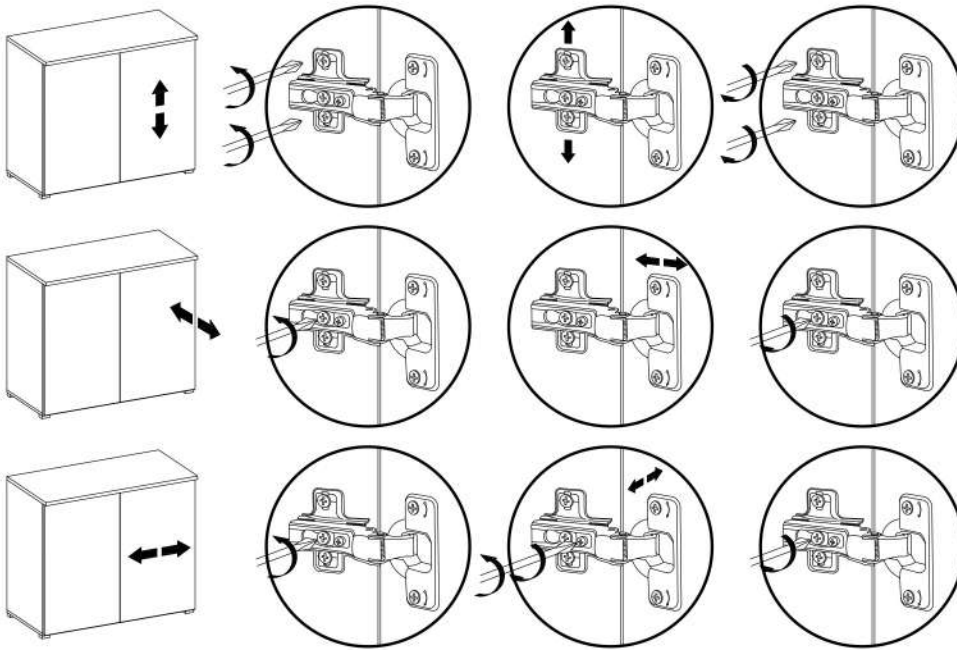

- (F) Mettre la porte (égaler les gonds)
- (I) Regolare la porta (livellare le parentesi)
- (D) Turen einstellen (Scharniere justieren)
- (GB) Adjusting the doors (adjusting the hinges)
- (NL) Deuren instellen (scharnieren afstellen)
- (PL) Nastawic drzwi (wyrównac zawiasy)
- (TR) Kapıların ayarlanması (mentşelerin seviye ayarı)
- (RU) Регулировка дверей (регулировка шарнира)
- (RO) Ajustați ușa (aliniati balamalele)
- (CZ) Seřid'te dveře (vyrovnajte závěsy)
- (SK) Zrad'te dvere (vyrovnajte závesy)
- (HU) Állítsa be az ajtóat (igazítsa be a zsanérokat)

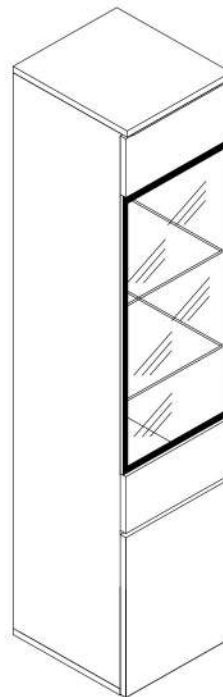
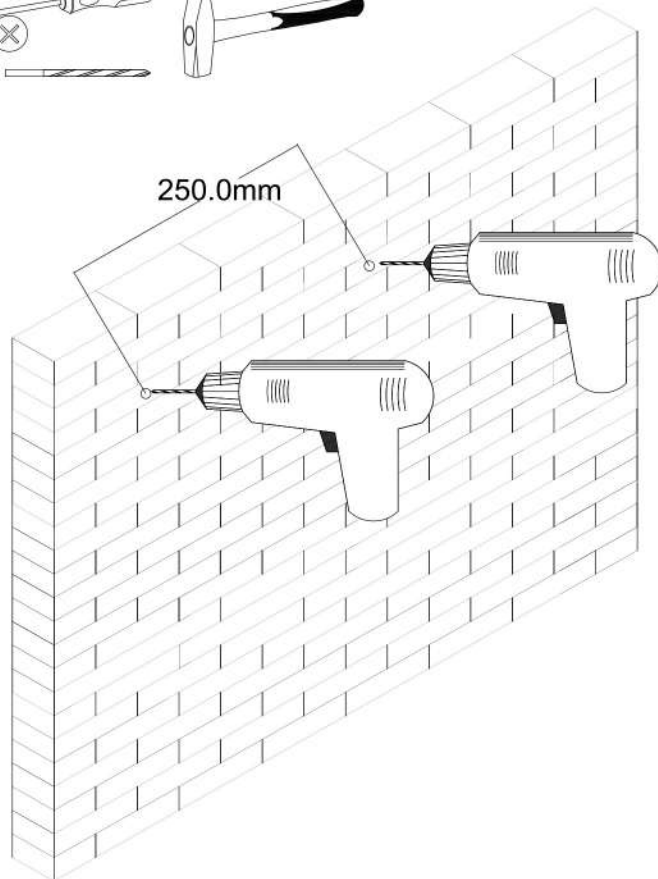
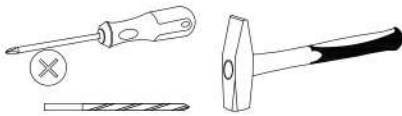

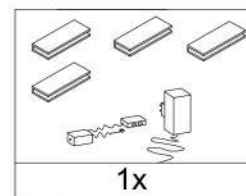
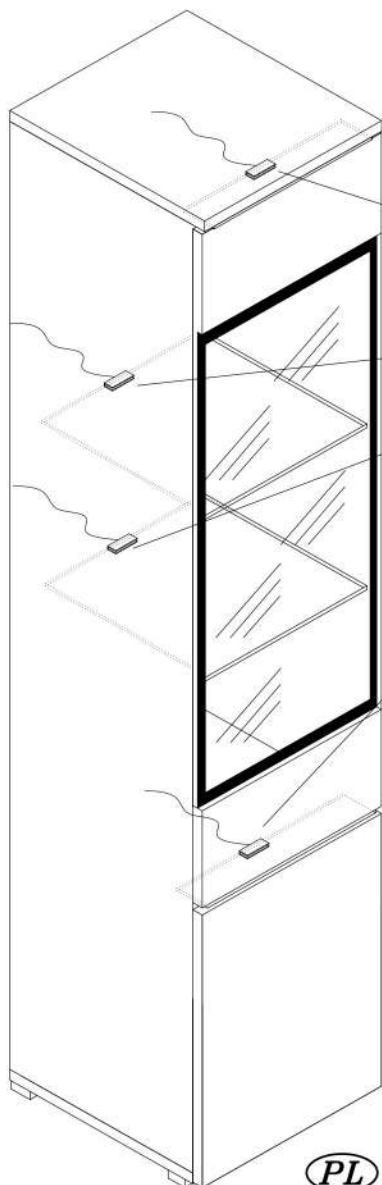

(PL) Uwaga: Punkty mocowania opcjonalnego oświetlenia

(CZ) Upozornění: body k připevnění doplňkového osvětlení

(D) Hinweis: Befestigungspunkte für optionale Beleuchtung

(GB) N.B.: Fixing points for optional lighting

(F) Remarque: Points de fixation de l'éclairage optionnel

(HU) Figyelem: Opcionális világítás rögzítési pontjai

(I) NOTA: punti di fissaggio opzionale dell'illuminazione

(NL) OPGELET: Optionele bevestigingspunten van de verlichting.

(RU) ВНИМАНИЕ: Точки крепления дополнительного освещения

(RO) Atenție: Punctele opționale de fixare a iluminatului

(SK) Upozornenie: body k pripavení dodatočného osvetlení

(TR) Dikkat: Seçenekli aydınlatmanın yerleştirilmesinin noktaları

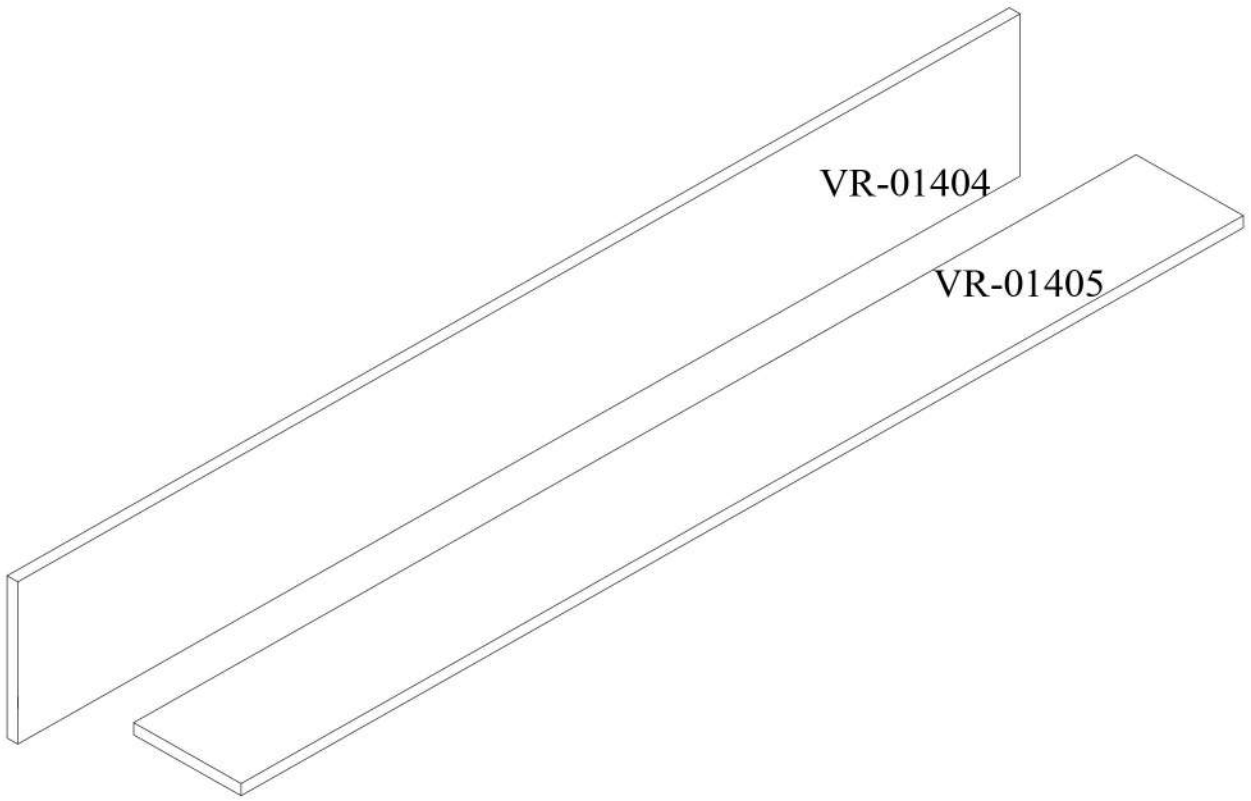

XII



8.0x30



D

4

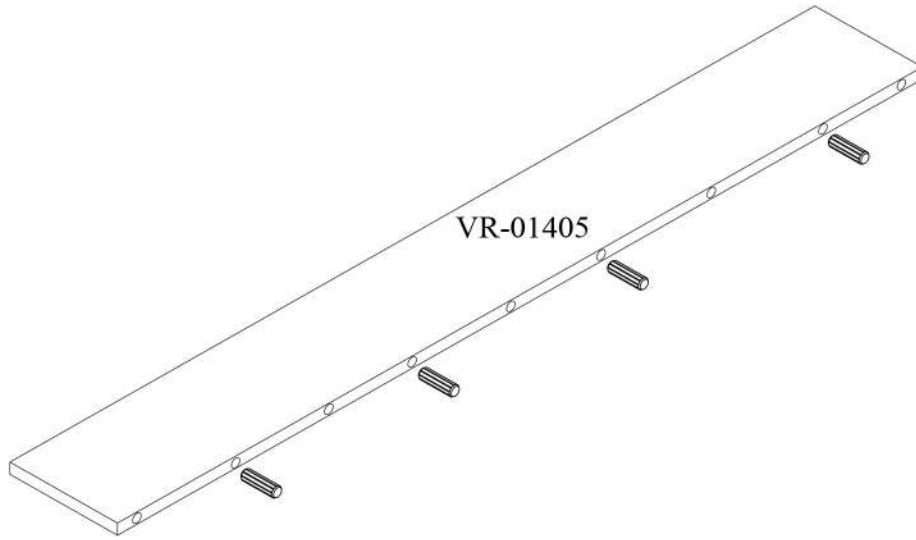

XIII

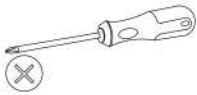

Y1

2



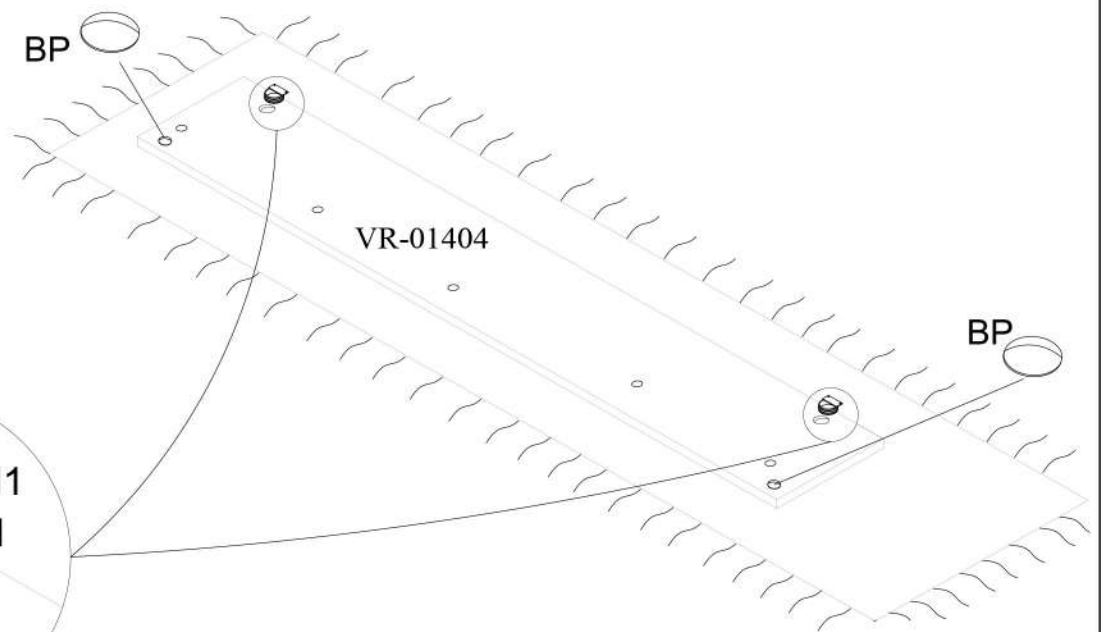

BP

2



XIV

	
1	5

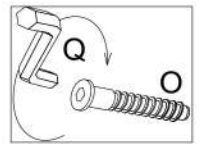
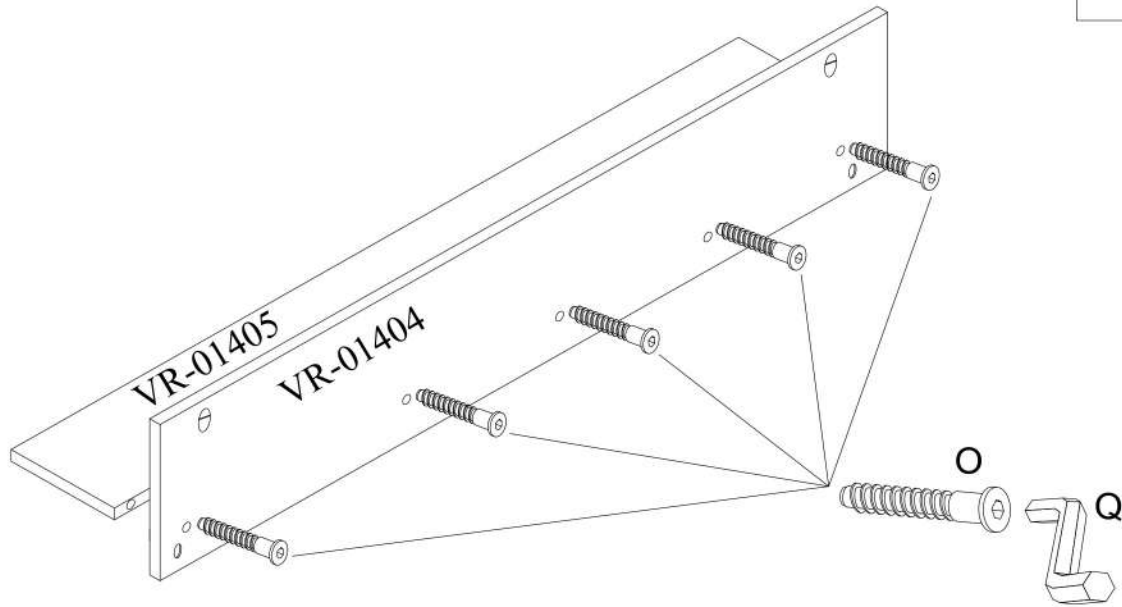

XV

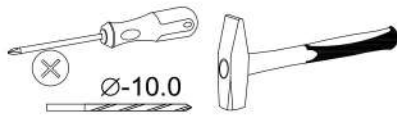

1

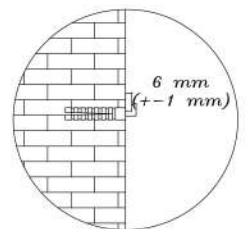
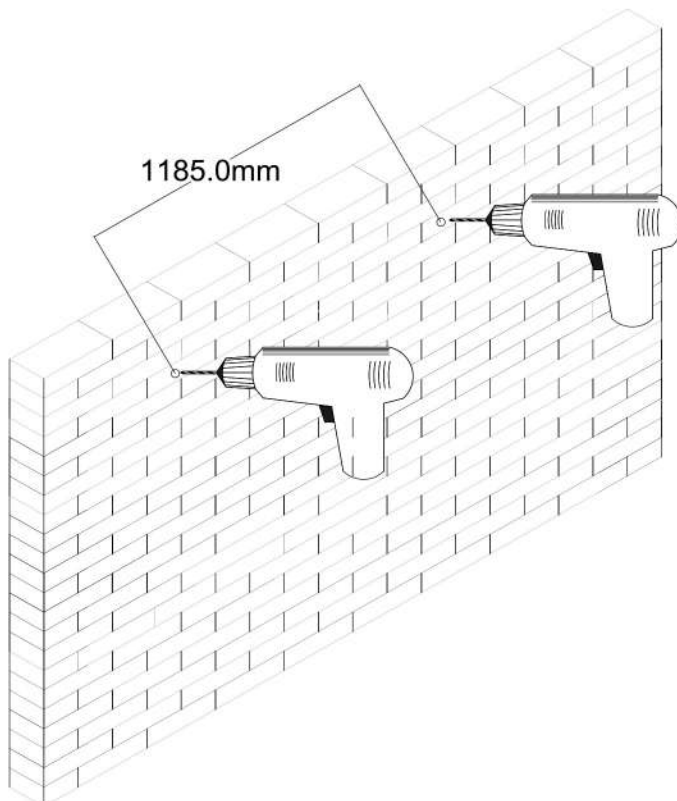

DE Möbel aus Naturholz und Plattenwerkstoffen
PL Meble z drewna naturalnego oraz płyt drewnopochodnych
NL Meubelen van natuurhout en plaatmateriaal
GB Furniture made from natural wood and panel materials
IT Mobili in legno naturale e materiali pannellati
FR Meuble en bois naturel et plaque en dérivé du bois
TR Doğal ahşap ve kereste malzemelerden üretilmiş mobilya
RU Мебель из натурального дерева, ДСП и ДВП
RO Mobilă din lemn natural și materiale fibrolemnoase
CZ Nábytek z přírodního dřeva a deskových materiálů
SK Nábytok z prírodného dreva a drevovláknitých doskových materiálov
HU Bútor természetes faanyagból és bútortalpokról

FR

Chère cliente, cher client, Merci pour votre commande !

Peu importe que vous ayez acheté un meuble fabriqué en bois naturel, un face haute brillance ou une face en plastique mat – chaque meuble a ses propriétés spécifiques. Même les propriétés et la structure du bois, comme par exemple les petits noeuds sur des meubles en bois naturel, font partie de l'aspect de chaque meuble. Comme le meuble en bois naturel est soumis aux variations permanentes du climat et de l'humidité, il se peut que quelques modifications surviennent sur la surface, comme par exemple de fines fissures ou des décolorations. En règle générale, au cours du temps, la clarté du bois diminue et son intensité de couleur augmente – le bois devient foncé. Les modifications susnommées sont un processus normal des matières naturelles comme le bois. Ce petit livret vous donne quelques astuces sur l'entretien de votre meuble pour que vous puissiez en profiter longtemps.

En règle générale :

- Ne pas poser d'objets chauds sur le meuble.
- Ne pas poser de bougies directement sur le meuble.
- Essuyer immédiatement les liquides renversés.
- À intervalles réguliers, contrôler que les vis et les ferrures sont bien en place.
- L'odeur aromatique typique du bois est toujours une preuve de qualité des meubles en bois naturel.
- Les endroits clairs sur les noeuds se produisent par une sécrétion naturelle de résine qui s'élimine avec un chiffon sec non pelucheux.
- Les autres matériaux comme le bois, la peinture, le cuir ou le rembourrage dégagent inévitablement une légère odeur. Ces odeurs disparaissent d'elles-mêmes avec le temps. Si vous souhaitez qu'elles disparaissent plus vite, au début, aérez plus souvent et essuyez les meubles avec un chiffon légèrement imbibé d'eau mélangée avec un peu de vinaigre.
- Conservez bien cette notice.

Instructions de soin pour les meubles lessivés/huilés en bois naturel La surface de votre nouveau meuble est traitée avec de l'huile purement biologique. Pour conserver le brillant de ce meuble lessivé/huilé, nous recommandons de faire un traitement occasionnel avec de l'huile à meuble. Comme le type de traitement de Surface peut éventuellement laisser des résidus d'huile naturelle, nous vous recommandons de frotter le meuble avec un chiffon non pelucheux. Après l'utilisation, laissez sécher le chiffon et ensuite le jeter.

Instructions de soin pour les meubles naturels/peints en bois naturel La surface se nettoie de préférence avec un chiffon légèrement humide. **Attention :** Les détergent agressifs ou à teneur en solvant ou les produits de polissage **ne doivent pas** être utilisés.

Consignes de soin pour les meubles avec des plaques en dérivé du bois Pour l'entretien de votre meuble en plaques en dérivé du bois, utilisez de préférence un chiffon doux non pelucheux ou une peau de chamois. Essuyez la surface légèrement humide. **En règle générale :** Veuillez n'utiliser **en aucun cas** les détergents suivants :

- **Chiffons à microfibres** ou **gomme à saleté**. Ils contiennent souvent de fine particules abrasives qui peuvent rayer les surfaces ;
- **substances chimiques agressives** ainsi que **des détergents abrasifs**. Ceux-ci peuvent également endommager les surfaces ;
- **poudre à récurer, paille de fer** ou **éponge grattant**. Elles détruisent la surface si profondément qu'il n'est plus possible de la retraiter ;
- **aspirateur**. Les buses et les brosses peuvent rayer la surface ;
- **nettoyeur à vapeur**. De fait de la haute pression et de la chaleur avec lesquelles la vapeur d'eau sort sur la surface, elles peuvent être endommagées et même décoller la base.

Votre service de développement de produits